

AMPLITUDE SHIFT KEYING

The most important and interesting concept in communication is Modulation. It has different types. Modulation is defined as the improving the signal characteristics amplitude, frequency or phase with reference of the carrier signal. If the input signal is analog form then such modulation is called as analog modulation. And if the inputs signal in the form of digital, such modulation is called Digital modulation. Analog forms of signals are suffered from distortion, noise and interference effects. Due to these three defects, digital signals are preferred than analog. And in digital modulation, the input signal is in the form of digital-only. It has only two voltage levels either high or low. But in the analog signal, its voltage is continued and affected by some type of noise. If the input signal in the form of digital and if you try to increase its amplitude characteristics concerning the carrier signal, this process of modulation is called as Amplitude Shift Keying. It is also known as ASK. This article discusses what is ASK, and its importance.

Amplitude Shift Keying Theory

This type of modulation comes under Digital Modulation schemes. Here, the word keying has some importance, i.e. Keying is indicating the transmission of digital signal over the channel. By the amplitude shift keying theory, we can understand the process of ASK technique.



analog-and-digital-signals

In ASK, it requires two input signals, First input is binary sequence signal and the second input is carrier signal. Here the most important point we need to always consider the second input which is the carrier signal has the more amplitude/voltage range than the input binary sequence signal.

Reason for Choosing the High Characteristics Carrier Signal

For example, if you want to go to someplace you can choose the bus for transportation purpose. Once you reached your destination you come out from the bus. Here when you reached your destination you are not considering the bus which you helped to reach your destination. You are using the bus as just for a medium. So, here also to complete the modulation process, the input binary sequence signal using the carrier signals to reach its destination point.

One more important point is to consider here, the carrier signal amplitude is should be greater than the input binary signal amplitude. Within carrier amplitude range we are going to modulate the binary input signal amplitude. If the carrier signal amplitude is less than the input binary signal voltage, then such a combination modulation process leads to over modulation and under modulation effects. So to achieve perfect modulation carrier single should have more amplitude range than input binary signal.

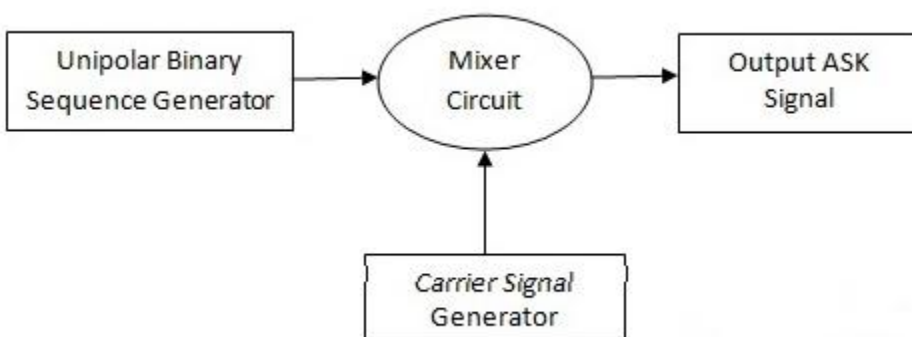

ask-block-diagram

In amplitude shift keying theory, input binary signal amplitude varies according to the carrier signal voltage. In ASK, the input binary signal is multiplied with the carrier signal along with its time intervals. Between the first time interval of input binary signal multiplied with the first time interval of carrier signal voltage and the same process continues for all time intervals. If the input binary signal is logic HIGH for certain time interval, then the same should be delivered at the output ports with increment in voltage level. So the main aim of the amplitude shift keying modulation is to changing or improving the voltage characteristics of the input binary signal concerning the carrier signal. The below diagram indicating the Amplitude shift keying block diagram.

At Mixer Circuit Level

When the switch is closed – for all the logic HIGH time intervals i.e. when the input signal having logic 1 during those intervals the switch is closed and it is multiplied with the carrier signal which is generating from the function generator for the same duration.

When the switch is opened – when the input signal having logic 0, the switch is opened and there is no output signal will be generated. Because the input binary signal logic 0 having no voltage, so during these intervals when the carrier signal multiplies with it, zero output will come. The output is zero for all logic 0 intervals of the input binary signal. Mixer circuit having the pulse shaping filters and band-limited filters for shaping the ASK output signal.

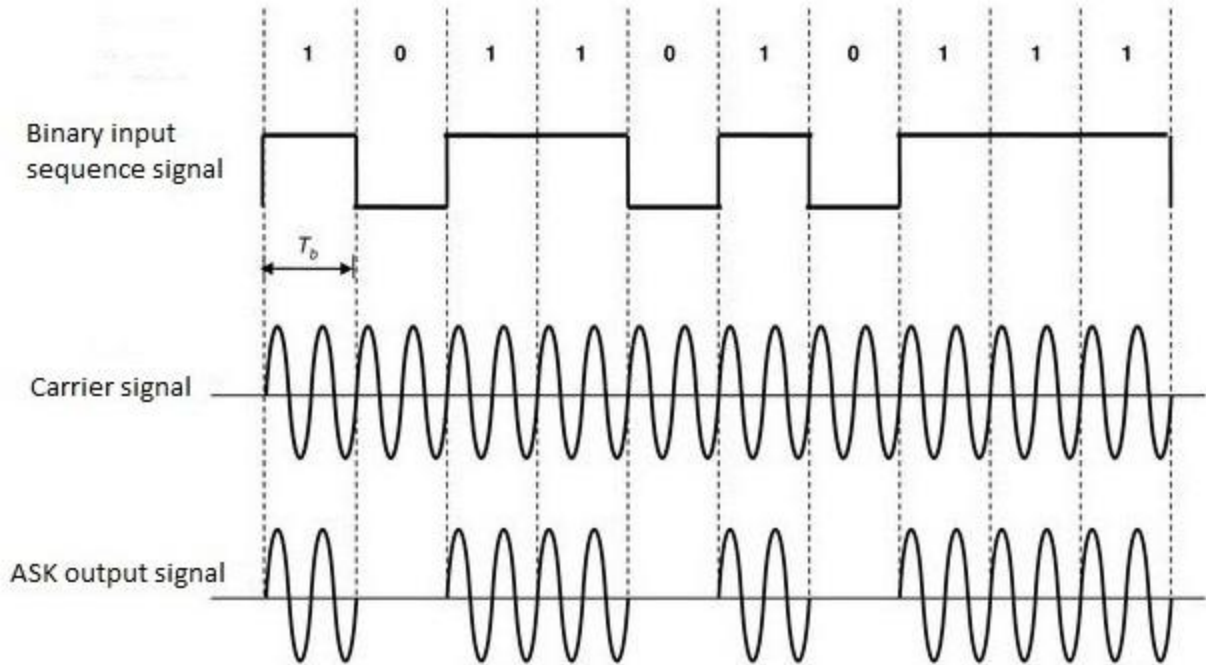

ask-modulation-waveforms

ASK Circuit Diagram

Amplitude shift keying modulation circuit can be designed with 555 timer IC as an astable mode. Here, the carrier signal can be varied by using the R1, R2 and C. The carrier frequency can be instantly calculated by the formulae as $0.69 \cdot C \cdot (R1 + R2)$. A PIN 4 we will apply the input binary signal and at PIN 3 the circuit will generate the ASK modulated wave.

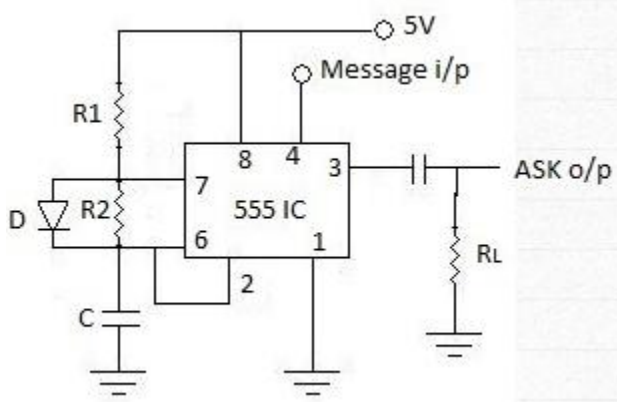

ask-modulation-circuit

ASK Demodulation Process

Demodulation is the process of reconstructing the original signal at the receiver level. And it is defined as, whatever the modulated signal received from the channel at the receiver side by implementing the proper demodulated techniques to recover/reproduce the original input signal at the output stage of the receiver.

ASK demodulation can be done in two ways. They are,

- Coherent detection (Synchronous demodulation)
- Noncoherent Detection (Asynchronous demodulation)

We will start the demodulation process with coherent detection which is also called as synchronous ASK detection.

1). **Coherent ASK Detection**

In this way of demodulation process, the carrier signal which we are using at the receiver stage is in the same phase with the carrier signal which we are using at the transmitter stage. It means the carrier signal at transmitter and receiver stages are the same values. This type of demodulation is called Synchronous ASK detection or coherent ASK detection.

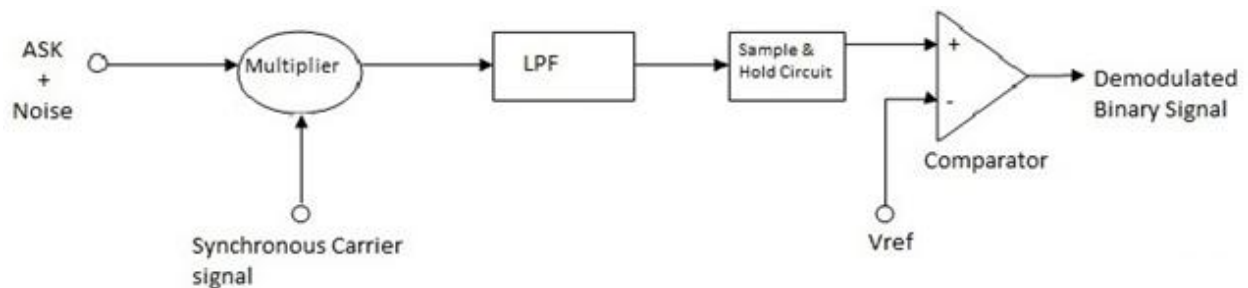

coherent-ask-detection-block-diagram

The receiver receives the ASK modulated waveform from the channel but here this modulated waveform is effected with noise signal because it is forwarded from the free space channel. So this, noise can be eliminated after the multiplier stage by the help of a low pass filter. Then it is forwarded from the sample and hold circuit for converting it into discrete signal form. Then at

each interval, the discrete signal voltage is compared with the reference voltage (V_{ref}) to reconstruct the original binary signal.

2). Non-coherent ASK Detection

In this, the only difference is the carrier signal which is using at the transmitter side and receiver side are not in the same phase with each other. By this reason, this detection is called as Non-coherent ASK detection (Asynchronous ASK detection). This demodulation process can be completed by using with square law device. The output signal which is generating from the square-law device can be forwarded through a low pass filter to reconstruct the original binary signal.

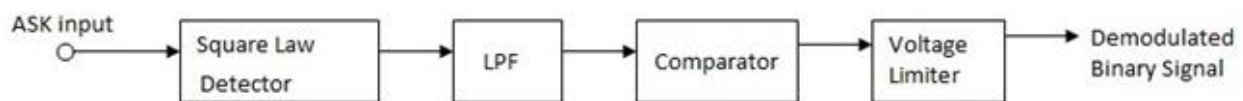

non-coherent-ask-detection-block-diagram

Amplitude shift keying is an effective technique to increase the input amplitude characteristics in communications. But these ASK modulated waveforms are easily affected by noise. And this leads to amplitude variations. Due to this, there will be voltage fluctuations in the output waveforms. The second drawback of the ASK modulation technique is, it has low power efficiency. Because ASK requires the excessive bandwidth. It leads to power loss in the spectrum of ASK.

Whenever to modulate two input binary signals, amplitude shift keying modulation is not preferable. Because it has to take only one input only. So, to overcome this Quadrature Amplitude Shift Keying (ASK) is preferred. In this modulation technique, we can modulate two binary signals with two different carrier signals. Here, these two carrier signals are in opposite phase with 90degrees difference. Sin and cosine signals are used as carriers in

quadrature amplitude shift keying. The advantage of this is, it uses effectively the bandwidth of the spectrum. It offers more power efficiency than the amplitude shift keying.

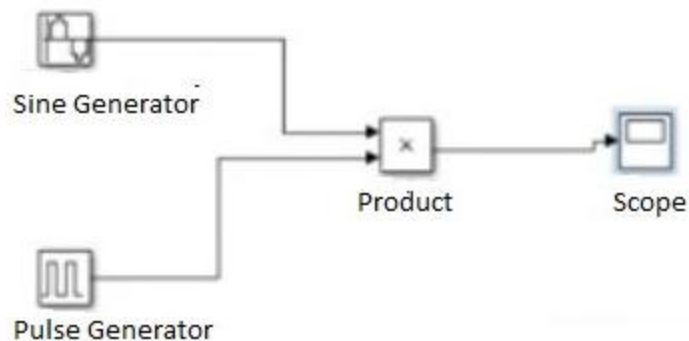

amplitude-shift- keying-Matlab-Simulink

Amplitude shift keying Matlab Simulink can be designed with Matlab tool. After initializing the tool, by following the proper steps we can draw the ASK circuit on the work area. By giving the proper signal values we can get the modulated output waveforms

ASK Applications

Modulation has an important role in communications. And amplitude shift keying applications are mentioned below. They are:

- Low-frequency RF applications
- Home automation devices
- Industrial networks devices
- Wireless base stations
- Tire pressuring monitoring systems

Thus, Ask (amplitude shift keying) is a digital modulation technique to increase the amplitude characteristics of the input binary signal. But its drawbacks make it so limited. And these drawbacks can be overcome by the other modulation technique which is FSK.