

## **UNIT – 2. CONVEYANCE SYSTEM**

Water supply -intake structures -Functions and drawings -Pipes and conduits for water-Pipe materials -Hydraulics of flow in pipes -Transmission main design -Laying, jointing and testing of pipes -Drawings appurtenances -Types and capacity of pumps -Selection of pumps and pipe materials.

### **CONVEYANCE OF WATER**

- ✚ Drawing off water from the source of water called intakes.
- ✚ Leading the water from intakes to the purification plants and then leading the treated water to the consumer through distribution pipes.

### **INTAKE STRUCTURE FOR WATER SUPPLY**

- Intake structures are the construction, used for storing the water, from surface sources (river, reservoir and lakes) and conveying it further to treatment plant.
- An intake may be nearer to water sources such as river, lake, etc.
- An intake is a structure which is constructed across the water source so as to permit the safe withdrawal of water from the water source. The structure may be stone, brick, RCC, or Concrete block masonry

### **Factors governing location of an intake**

1. The location of intake structure should be nearer to the treatment plant, in order to reduce the cost of conveyance water.
2. The location of the intake should be selected in a place, where there is the less impurities presence.
3. The intake should be selected at a place from where the water can be taken during driest season of the year also.
4. The intake location should have the possibility for future expansion and addition without much increase in cost.
5. The intake should not be located at the downstream of the disposal point of sewage.
6. It should be located in such a way that, it should not be affected by heavy flood and the flood should not enter through the intake.
7. The intake should not be located near the navigation channels such as Harbour etc.
8. It should not be interference with river traffic if any.

## DESIGN CONSIDERATIONS

Sl.No	Criteria	Design considerations
1	Factor of safety	Against all external forces (Forces by floating materials, pressure, heavy currents etc)
2	Self-weight	To withstand water pressure
3	Safety	If located near the navigation channels
4	Sub structure	Foundation design against water pressure
5	Size	Considerable ( Suitable with future expansions )

### Type of intake structures

- ✘ Simple submerged Intake
- ✘ Intake Tower or River Intake Structures
  - + Wet Intake Towers
  - + Dry Intake Towers
- ✘ Reservoir Intake
  - + Variable depth lake water intake
  - + Multi-level intake
- ✘ Canal Intake Structures.

### 1. SIMPLE SUBMERGED INTAKE

- ☒ A submerged intake structures consists of simple concrete block or a rock filled timber crib supporting the starting end of the withdrawal pipe.
- ☒ The withdrawal pipes are generally taken up to the sump well at shore from where the water is lifted by pumps.
- ☒ The intake opening is generally covered by screen so as to prevent the entry of debris, ice etc., into the withdrawal pipe.
- ☒ In case of lakes where silt tends to settle down, the intake opening is generally kept about 2 to 2.5 m above the bottom of the lake and thus to avoid the entry of silt and sediment.
- ☒ Such intake structures should be placed in streams or intakes at a place where they may not get buried under sediment and where there are deep water.

- ⊗ These are widely used intakes for small water supply projects drawing water from streams and lakes having relatively little change in water surface elevation throughout the year.

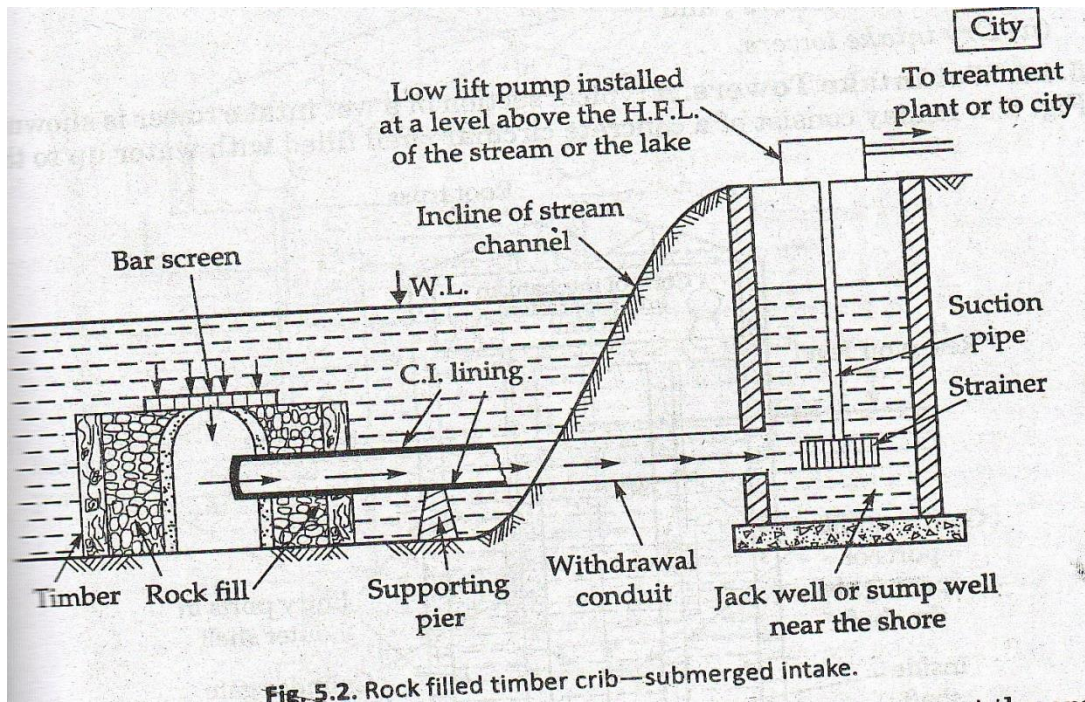
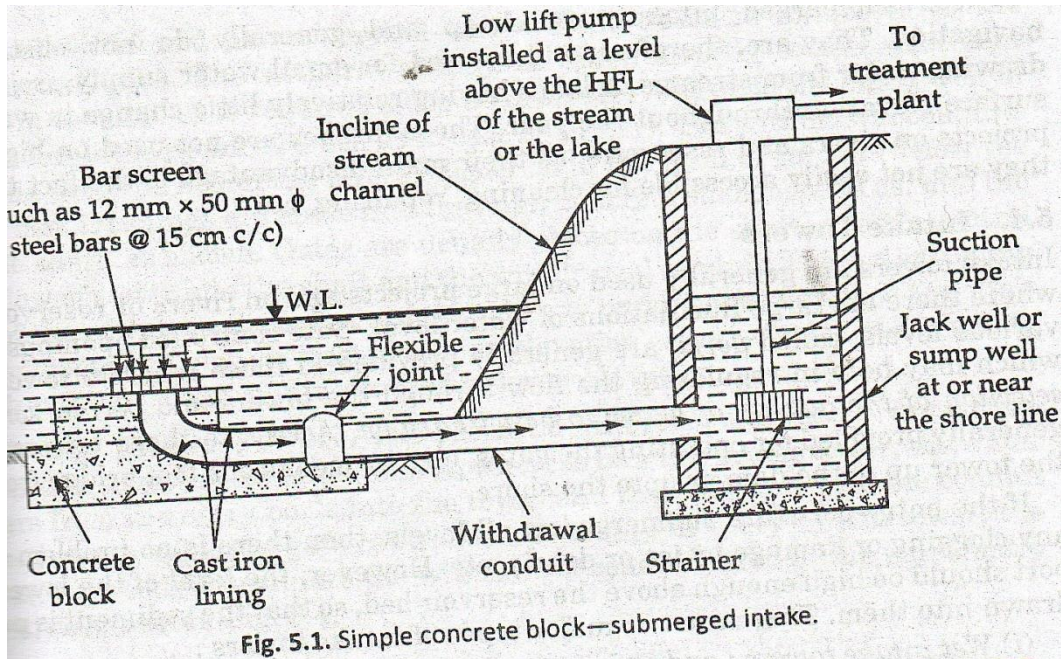

## 2. INTAKE TOWERS OR RIVER INTAKE STRUCTURES

- ⊗ Intake towers are generally used on large projects and on rivers or reservoirs where there is large fluctuation of water level.

- ✘ Gate controlled openings at various levels called ports are generally provided in these concrete towers which may help in regulating the flow through the towers and permit some selection of the quality of water to be withdrawn.
- ✘ Accesses to these towers are generally provided for operating the gates, etc., by means of a foot bridge from the tower up to the dam or up to the shore.

### Types of Intake Towers (river)

- + Wet intake Towers
- + Dry Intake Towers

#### *Wet Intake Tower*

- ✘ The wet intake is that type of intake tower in which the water level is practically the same as the level of source of supply.
- ✘ It is sometimes known as JACK Well and it is most commonly used.
- ✘ It consists of a concrete circular shell filled with water up to the reservoir level and has a vertical inside shaft which is connected to the withdrawal pipe.

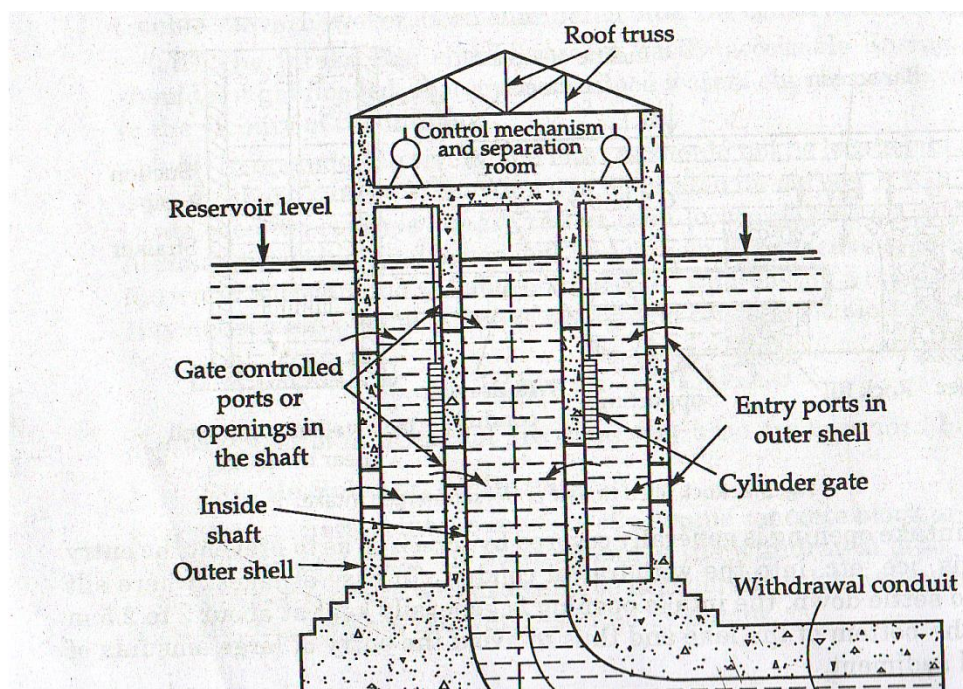

#### **Dry Intake Tower**

- ✘ The essential difference between a dry intake and wet intake is that in a wet intake the water enters from the entry ports in to the intake and then it enters in to the conduit pipe through separate gate controlled openings whereas in a dry intake water is directly drawn in to the withdrawal pipe through the gate entry openings.
- ✘ A dry intake will therefore have no water inside the intake if its gates are closed whereas the wet intake will be full of water even if its gates are closed.

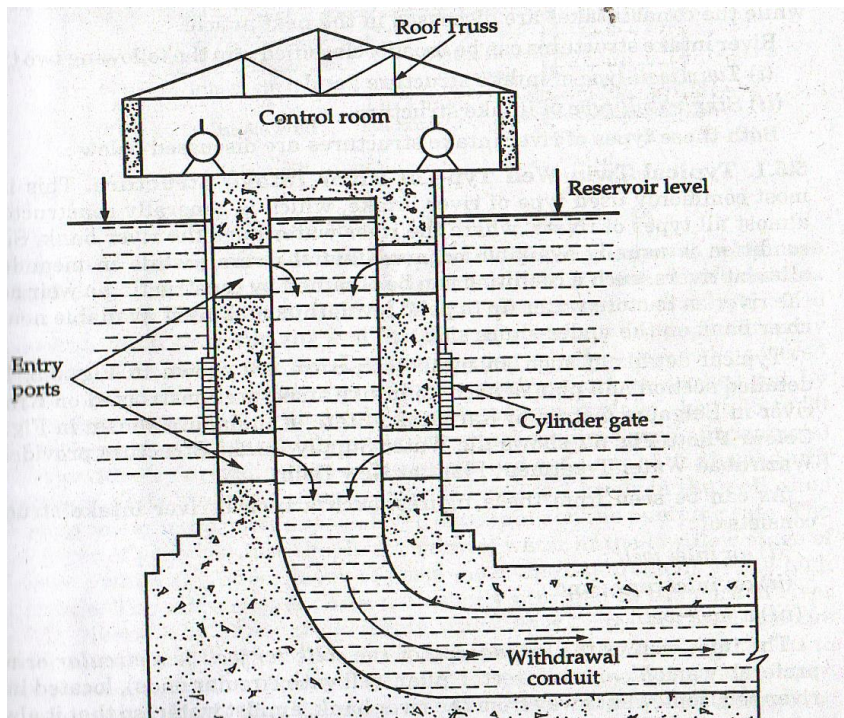

### 3. RESERVOIR INTAKES

- ✘ When the flow in the river is not get guaranteed throught the year a dam is constructed across it to store water in the reservoir so formed.
- ✘ The reservoir intakes are practically similar to the river intake except that these are located near the upstream face of the Dam where maximum depth of water is available.
- ✘ The access to intake is provided through a foot bridge.
- ✘ The water level will be the same as the reservoir level.

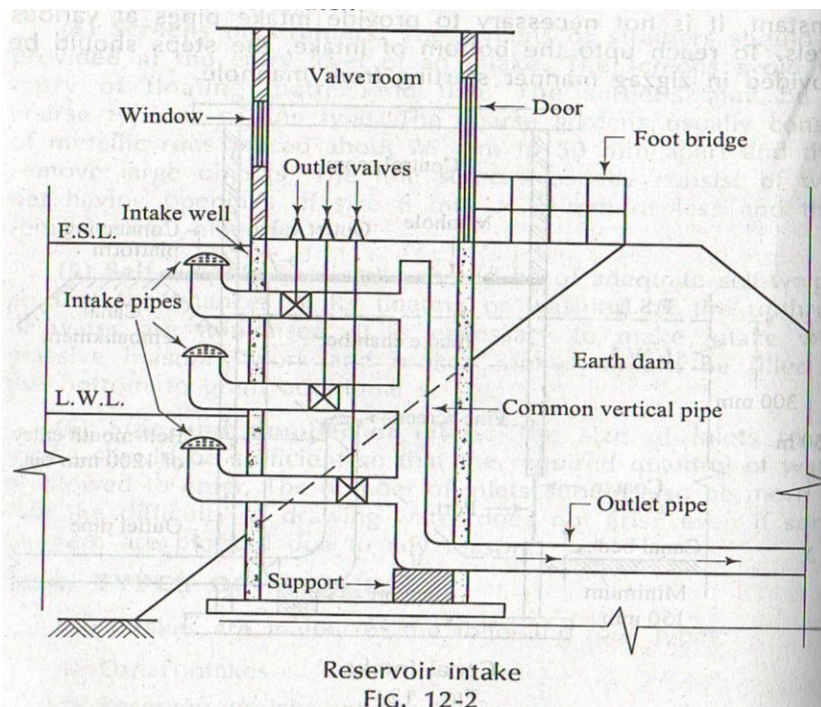

#### 4. CANAL INTAKE

- ✘ In canal intake structure, the intake well is generally located in the bank of the canal and water enters the chamber through the inlet pipe.
- ✘ The inlet pipe is covered with a fine screen.
- ✘ The top of the screen is generally provided at minimum water level in the canal and bottom is about 0.15 m above the canal bed to avoid entry of bed load.
- ✘ The inlet end is of bell mouth shape with perforation of fine screen on its surface.
- ✘ The flow velocity through the outlet is generally 1.5 m/sec, and this helps in determining the area and diameter at the withdrawal pipe.
- ✘ The area of the coarse screen is designed by limiting the flow velocity to as low as 0.15m/sec.
- ✘ The flow velocity through the bell mouth is limited to about 0.3 m/sec.

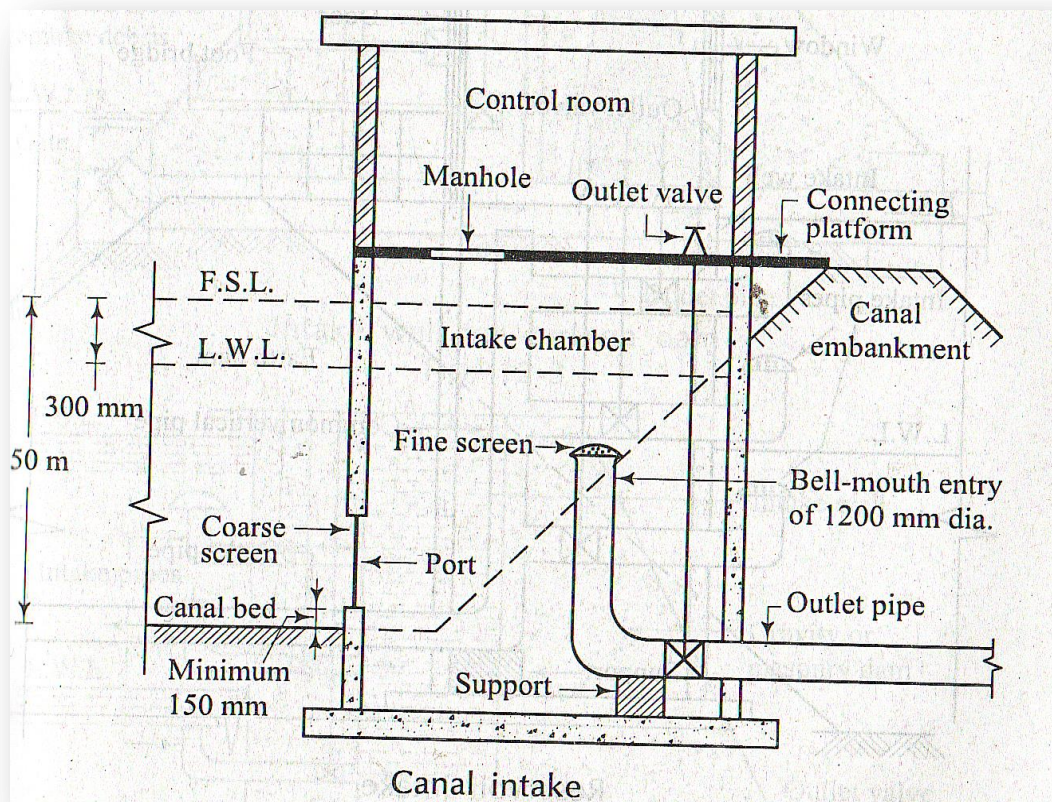

#### DESIGN OF INTAKES

- ✘ Pipe is a circular closed conduit through which the water may flow either under gravity or under pressure. They may be gravity conduit or may be pressure conduits.
- ✘ Gravity conduit- Open channel, Flume & Aqueducts
- ✘ Pressure conduit- Pipe
- ✘ Discharge through pipe  $Q = A \times V$ 
  - Where  $V$  is velocity in the pipe,  $A$  is cross sectional area of the pipe.
- ✘ Diameter of the pipe is worked with the help of modified Darcy-Weisbach formula

$$h_f = \frac{fLQ^2}{12.1d^5}$$

Where,  $h_f$  = head loss due to friction

$f$  = co-efficient of friction

$L$  = length of pipe

$Q$  = Discharge through pipe

$d$  = diameter of pipe.

### OPEN CHANNEL

- ✘ These are rarely used to transport the water from the source to treatment plant.
- ✘ These can be effortlessly and cheaply constructed by cutting in elevated grounds and banking in low grounds.
- ✘ As water flows only due to gravitational force a uniform slope should be given.

### FLUMES

- ✘ The flumes are open channels, but the ground is supported by trestles etc.
- ✘ The use of flumes is to transport the water across valleys and minor low lying areas or over drains and other obstructions.

### AQUEDUCTS

- ✘ Aqueducts are channels either above ground, below ground or on the ground that transport water from a lake or stream into a water treatment unit which may be miles away.
- ✘ The average velocity will be in the range between 1.0 to 1.5 m/sec.

### Stresses in the Pipe

1. Stresses due to change of direction
2. Stresses due to internal water pressure
3. Stresses due to soil above the pipes
4. Stresses due to water hammer
5. Stresses due to yielding of soil below pipes and
6. Temperature stresses.

The final selection of material for the pipe is done by considering various factors such as availability of funds, type of water to be conveyed, carrying capacity of pipes, maintenance, cost and durability.

## **Various materials used for pipes**

1. Asbestos cement pipes
2. Cast-iron Pipes
3. Cement concrete pipes
4. Copper pipes
5. Galvanised pipes
6. Lead pipes
7. Plastic pipes
8. Steel pipes
9. Steel pipes
10. Wood pipes

### **1. Asbestos cement pipe**

- ✗ Made from mixture of Asbestos fibre and cement.
- ✗ Convey water under low pressure.

#### **ADVANTAGES:-**

- + Inside surface- Very smooth
- + Joining- Very good, flexible, easily
- + Light in weight, easy to handle & transport
- + Very suitable for distribution pipes of small size

#### **DISADVANTAGES:-**

- + Brittle; cannot withstand impact forces
- + Not durable
- + Cannot be laid in exposed places
- + Can be used only for very low pressure.

### **2. Cast iron pipes**

- ✗ Mainly used for conveyance of water.
- ✗ Joined by bell and spigot (or) Expansion joint.
- ✗ The spigot is of smaller diameter and is inserted to the larger diameter bell end.
- ✗ Expansion Joint: Severe change of temperatures
- ✗ A rubber gasket is inserted between the spigot and the bell end.
- ✗ Flanged joint: Water at high pressure. At a wide flange will be provided which are bolted together.
- ✗ They are manufactured by pig-iron and given some suitable treatments

#### **ADVANTAGES**

- + The cost is moderate
- + Easy to join
- + Not subjected to corrosion



- + Strong & Durable

### **DISADVANTAGES**

- + The breakage of these pipes is large.
- + Carrying capacity decreases with the increases in life
- + Not used for pressure greater than  $0.7 \text{ N/mm}^2$
- + Heavier & Uneconomical- Size beyond 1200 mm dia.

### **3. Cement concrete pipes**

- ✗ Plain (or) Reinforced (or) Pre stressed pipes
- ✗ Plain – 15 m , RCC – 75 m and High head – pre stressed.
- ✗ Reinforcement in the form of links or hooks and longitudinal bars
- ✗ Mould - Hume pipe (or) Spun concrete pipes

### **ADVANTAGES**

- + Inside Surface – Very smooth
- + Maintenance cost is low
- + Pipes can be cast at site and can be transported.
- + Does not require expansion joint
- + No danger of rusting & incrustation

### **4. Copper pipes**

- ✗ Widely used for service connections

### **ADVANTAGES:-**

- + Cheap, light in weight and easy to handle and transport.
- + Easy to join

### **DISADVANTAGES**

- + Liable for incrustation & easily affected by acidic or alkaline water.
- + The useful life of pipe is short about 7 to 10 years.

### **5. Lead pipes**

- ✗ Not adopted for conveyance of water due to lead poisoning
- ✗ It can be easily bent.
- ✗ Apparatus required for alumina & chlorine discharge- can not water.
- ✗ It can be bent due to hot water.

### **6. Plastic pipes**

- ✗ LDPE- Low Density Poly Ethylene Pipes- Flexible
- ✗ Strong in resisting acids
- ✗ PVC- Poly Vinyl Chloride Pipes three times as rigid as poly ethylene pipe.

## **ADVANTAGES**

- + Freedom from damage due to thawing & freezing
- + Pipes are very cheap
- + Durable & Hydraulic resistant
- + Free from corrosion
- + Good electric insulator
- + Light in weight easy to bend

## **DISADVANTAGES**

- + Co-efficient of expansion for plastic is high
- + Difficult to obtain the plastic pipes of uniform compositions
- + Less restraint to heat
- + Some type- impart to the taste of water.

### **7. Steel pipes**

- × Mild steel is used for steel pipes
- × Joints – Riveted or Welded
- × Generally used for more than 1200 mm dia
- × Inside generally galvanized.

#### **ADVANTAGES**

- + Available in long length- No of joints less
- + Cheap & Best in cost
- + Durable & Strong
- + Flexible to some extent & laid easily on curves
- + Light in weight & easy to transport.

#### **DISADVANTAGES**

- + Maintenance cost is high
- + Rust attack due to alkali water
- + Require more time for repairing
- + Deform shapes under combined action of internal and external load.

### **8. Wood pipes**

- × Usually prepared of staves or planks wood held together by steel bands.
- × Light in weight cannot bear higher pressure
- × Rarely adopted for conveyance of water.

### **9. Wrought Iron pipe**

- × Light in weight can be easily cut threaded and worked.
- × Costly and Less durable. Not generally used in water conveyance system.

## **JOINTS IN PIPE**

Pipe joints are the assemblies used to connect one pipe with other without any leakage or other losses.

### **CLASSIFICATION**

#### **1. Based on the Rigidity & Flexibility**

- ✘ Rigid Joint
- ✘ Semi Rigid Joint
- ✘ Flexible Joint

#### **2. Based on Functions & location**

- ✘ Spigot and Socket Joint
- ✘ Expansion Joint
- ✘ Flanged Joint
- ✘ Screwed Joint

### **Rigid joints**

- ✓ Rigid Joints are those which admit no movement at all and comprise flanged, welded and turned and bored joint.
- ✓ Flanged joints require perfect alignment and close fittings and are frequently used where a longitudinal thrust must be taken such as at the valves and meters.
- ✓ The gasket used between the flanges of pipes shall be compressed fibre board or natural or synthetic rubber.
- ✓ Welded joints produce a continuous line of pipe with the advantage that interior and exterior coatings can be made properly and are not subsequently disrupted by the movement of joints.

### **Semi rigid joints**

- ✓ A semi rigid joint allows partial movement due to vibration etc.
- ✓ The socketed end of the pipe should be kept against the flow of water and the spigot end of the other pipe is inserted in to this socket .
- ✓ A rope is then placed at the outer end of the socket and is made by tight fit by applying wet clay leaving two holes for the escape of the entrapped air inside.

### **Flexible joints**

- ✓ Flexible joints are used where rigidity is undesirable such as filling of granular and when two sections cannot be welded.
- ✓ They comprise mainly mechanical and rubber ring joints which permit some degree of deflection at each joint and are therefore able to withstand vibration and movements.

- ✓ In the rubber jointing special type of rubber gasket are used to connect cast iron pipe which are cast with a special type of spigot.
- ✓ Rubber joint is to be preferred to lead joining

### **Spigot & socket joint**

- ✓ This is mostly suitable for cast iron pipes
- ✓ This type of joint is connected by inserting the spigot end of one pipe in to the socket or bell end of the other.
- ✓ The connecting procedure includes; wrapping of jute around the spigot before inserting it in to the socket.
- ✓ Then in the remaining space or gap between spigot and socket is filled by molten lead.
- ✓ Cooling time will be given for the solidification of molten lead.
- ✓ The flexibility of this joint is less and need skilled labour.

### **Expansion joint**

- ✓ The main advantage of the expansion joints is its flexibility.
- ✓ In some cases the pipes are laid over the ground and exposed to the atmosphere.
- ✓ Due to thermal stresses the pipe will tend to expand and contract which ultimately results in the formation of cracks in the external surface of the pipe and leak in the joints.
- ✓ In this type of joint the socket end is connected rigidly to an annular ring which can freely over the spigot joint.
- ✓ The provision of gasket will aid the pipe movement at the time of expansion due to thermal stress.

### **Flanged joint**

- ✓ This type of joint mostly used for temporary pipe network.
- ✓ The pipe has flanges at both the ends .This ends are connected by bolts and nut or welding.
- ✓ During the connection process a rubber gasket is placed between the two ends which will prevent leakage.
- ✓ This joint is commonly used in plumbing station boiler house etc.
- ✓ But if this joint is used in steel pipe it will be better to connect by nuts and bolt rather by other connection.

### **Screwed joint**

- ✓ The screwed joints are usually adopted when the pipe diameter is less
- ✓ In this joint the ends of the pipes are threaded outside, while socket or coupling has threads on both the ends of the pipe to join them.
- ✓ For making water tight zinc paint or hemp yarn should be placed in the threads of the pipe, before screwing socket over it.

## LOSSES IN PIPE FLOW

1. Major Loss – Due to friction – Darcy’s formula  $h_f = \frac{fLv^2}{2gd}$

2. Minor Losses –Due to pipe arrangements and flow direction

$$h_m = k \frac{v^2}{2g}$$

**k value will be**

Sl.No	Description	K value
1	Sudden Contraction	0.3 - 0.5
2	Entrance	0.5
3	Elbow 1. 90 degree 2. 145 degree 3. 220 degree	0.50 to 1.00 to 0.40 to 0.75 to 0.25 to 0.50
4	Tee 1. 90 degree 2. Straight runner 3. Coupling	1.5 0.3 0.3
5	Gate valve (open)	0.3 to 0.4
6	Reducer and Increaser	0.5
7	Globe	10.00
8	Angle	5.00
9	Swing check	2.5
10	Venturimeter	0.3
11	Orificemeter	1.00

## PIPE CORROSION

- ✚ Loss of pipe materials due to the action of water
- ✚ Metallic structure of the pipe is attacked and dissolved by water.
- ✚ Action of water flowing through the pipe
- ✚ Action of water logged in the soil above the pipe

### Factors

1. Acidity, Alkalinity
2. Biological action
3. Chlorination
4. Electrical current
5. Oxygen
6. Mineral and organic constituents

### **Effects of pipe corrosion**

1. Tuberculation- Formation of small projection inside the surface of the pipeline- pipe carrying capacity is reduced.
2. Disintegration of pipeline – Demand heavy repairs
3. Effects on colour, taste & odour to the water
4. Affecting seriously the pipe connections
5. Water dangerous for drinking purposes.

### **Theories of pipe corrosion**

1. Action of water motion
2. Bimetallic action
3. Biological action
4. Chemical reaction
5. Electrolysis

### **Prevention of pipe corrosion**

1. Cathodic protection
2. Proper pipe materials
3. Protective lining
4. Treatment of water

### **PIPE APPURTENANCES**

1. Sluice valve or Gate valve
2. Air valves
3. Reflux valves
4. Relief valves
5. Altitude valves
6. Scour valves
7. Fire Hydrants
8. Bib cocks
9. Stop cocks
10. Water meters

#### **1. Sluice valve or Gate valve**

- ✿ It is used to control the flow of water and helpful in dividing the water mains into the suitable sections.
- ✿ They are generally placed at a distance of about 150mm-200mm and at all the junction.
- ✿ They are made of cast with brass mounting.
- ✿ They are solid wedge type (or) double disk.

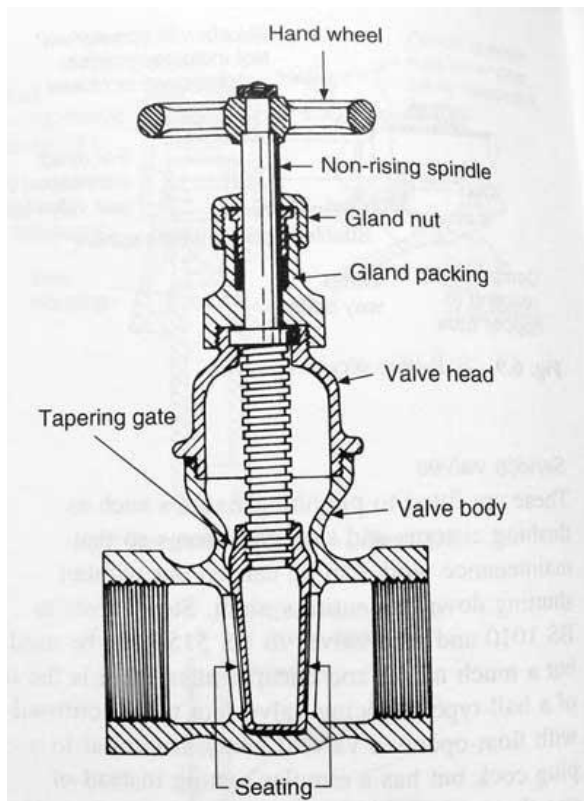

## 2. Air valves

- ✿ They are normally called air relief valves.
- ✿ To provide an exit of air, these valves are provided.
- ✿ Located very close or above the hydraulic gradients.
- ✿ It consists of a cast iron chamber, float, lever and poppet.



### 3. Reflux valves

- These are also known as automatic cut off valves (or) safety valves.
- They are located at every point along the water pipe where pressure is likely to be maximum .
- Where pressure of water exceeds a predetermined limit, the valve operate automatically and it will save a particular section of water pipe before bursting the pipe.

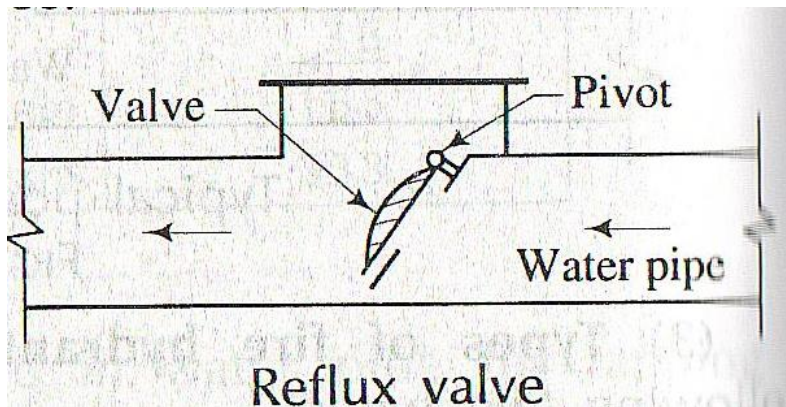

### 4. Relief valves

- These are also known as automatic cut off valves or safety valves.
- They are located at every point along the water pipe where pressure is likely to maximum.
- When pressure of water exceeds a predetermined limit the valve operates automatically and it will save a particular section of water pipe before bursting the pipe.

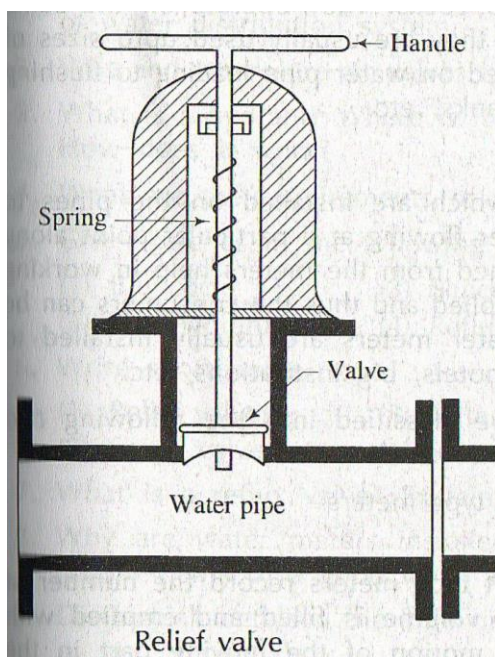



## 5. Altitude valves

- ✿ They are mainly used on those lines which supply water to elevated tanks or stand pipes.
- ✿ They close automatically when the tank is full and open when the pressure on the pump side is less than that on the tank side of the valve.

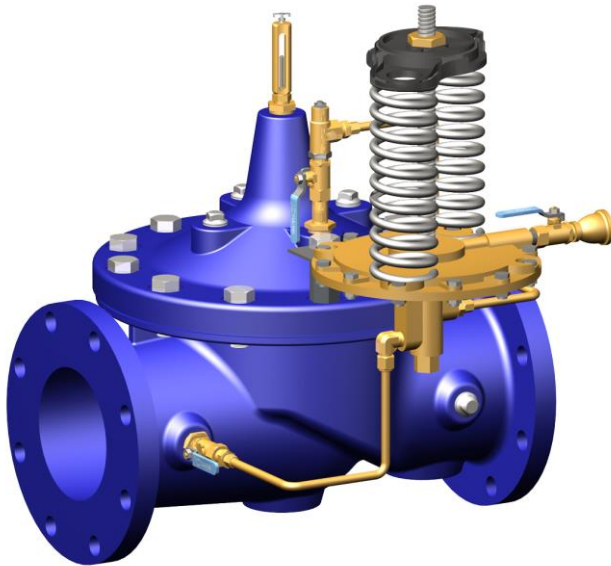

## 6. Scour valve

- ✿ Scour valves (or) blow off (or) washout valves are ordinary sluice that located either at the dead end or at lowest points in the main.
- ✿ They are provided to blow off or remove sand and silt deposited in the pipeline.
- ✿ They are operated manually.



## 7. Fire hydrants

- ✿ A hydrant is an outlet provided in water pipe for tapping water mainly in case of a fire.
- ✿ Fire hydrant is used for fire fighting purposes.
- ✿ They are placed at all junctions and so located that if a circle of about 60 to 90 m drawn from any hydrant.

### Type of Hydrants:-

1. Flush Hydrant
2. Post Hydrant



### **Requirements of a fire hydrant**

1. It should be cheap
2. Easily detectable in case of fire
3. It can be easily connected with the hose motor pump
4. It should function properly and should not go out of order during operation.
5. It should permit undisturbed flow of water when being fully opened.

## 8. Bib cock

- ✿ These are water taps which are attached at the end of water pipes and from which the consumer obtain water.
- ✿ It is operated from a handle.
- ✿ They may also push type and they operate automatically.
- ✿ They should be water tight; the leaky bib cocks are the source of waste water.



### 9. Stop cocks

- ✿ These are small size sluice valves and they are installed in service pipes, serving the bib cocks.
- ✿ They operate on the same principles of sluice.
- ✿ They are placed on water pipes leading to flushing tanks, wash basins, water tanks etc.



### 10. Water meter

These are devices which are installed on the pipes to measure the quantity of water flowing at a particular point along the pipe.

They usually installed at to supply water to industries, hotel, big institutions etc.

## Types

1. Positive displacement type meter
2. Velocity meter
  - ✿ They should accurately measure discharge(2% tolerance)
  - ✿ They should easy to repair and maintenance
  - ✿ Should not too costly
  - ✿ They should be non corrosive.



## WATER DISTRIBUTION SYSTEM

### Lay out of Water Distribution System

1. Dead end system (or) Tree System
2. Grid- iron system (or) Reticulation System
3. Circular System (or) Ring System
4. Radial System.

#### 1. Dead end or tree system

- ✿ One main pipe line runs through the center of the populated area and sub-mains takeoff from this to both sides.
- ✿ The sub-mains divide into several branch lines from which service connections are provided.

## Advantages

- i. The design calculation is simple and easy.
- ii. A smaller number of cut-off valves are required and the operation and maintenance cost is low.
- iii. Pipe-laying is simple.

## Disadvantages

- i. The system is less successful in maintaining satisfactory pressure in the remote areas and is therefore not favored in modern waterworks practice.
- ii. One main pipeline provides the entire city, which is quite risky. Any defect, damage or breakage at one point of this line will disrupt the supply of water beyond that point, cutting off service to the whole area. This could be dangerous, especially if there is a fire.
- iii. The head loss is relatively high, requiring larger pipe diameter, and/or larger capacities for pumping units.
- iv. Dead ends at line terminals might affect the quality of water by allowing sedimentation and encouraging bacterial growth due to stagnation. Water hammer could also cause burst of lines. A large number of scour valves are required at the dead ends, which need to be opened periodically for the removal of stale water and sediment.
- v. The discharge available for firefighting in the streets will be limited due to high head loss in areas with weak pressure.

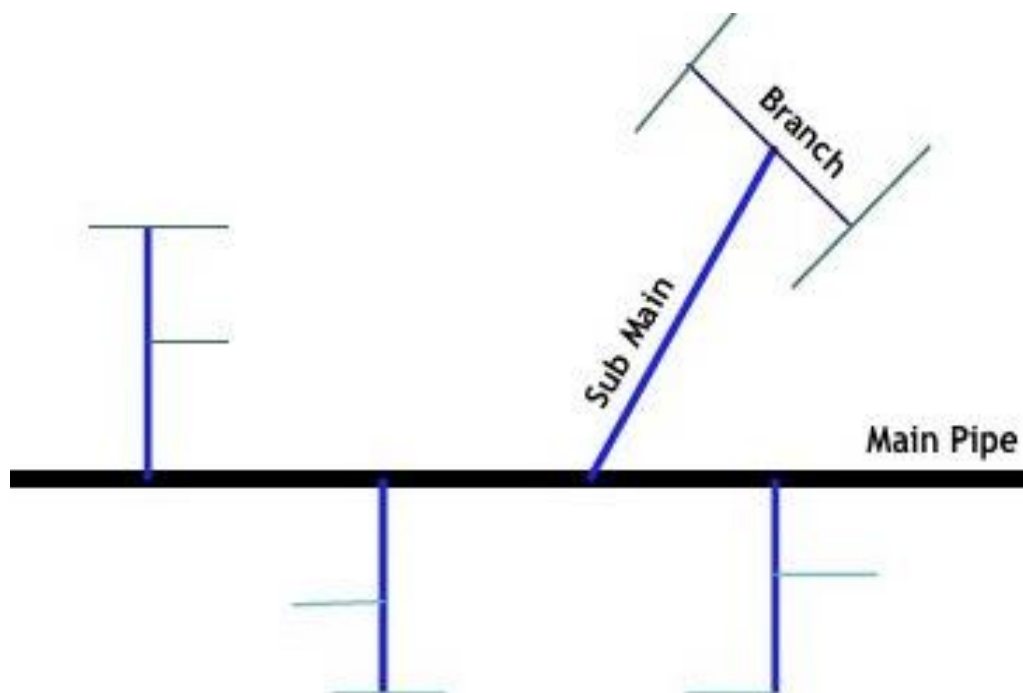

## 2. Gridiron system

- ✿ In Gridiron system the main supply line runs through the center of the area and submains takeoff from this in perpendicular directions. The branch lines interconnect the sub-mains.
- ✿ This system is ideal for cities laid out in a rectangular plan resembling a grid iron.
- ✿ The distinguishing feature of this system is that all of the pipes are interconnected and there are no dead ends.
- ✿ Water can reach a given point of withdrawal from several directions, which permits more flexible operation, particularly when repairs are required.

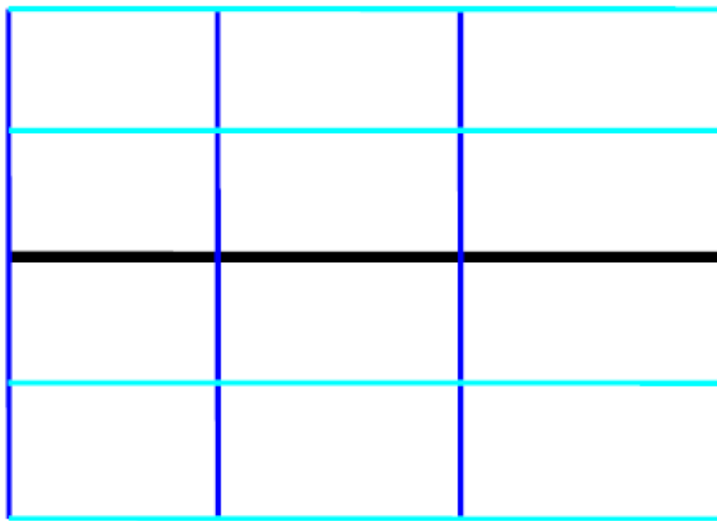

**Figure 2: Gridiron distribution system**

### Advantages

- i. The free circulation of water, without any stagnation or sediment deposit, minimizes the chances of pollution due to stagnation.
- ii. Water is available at every point, with minimum loss of head, because of the interconnections.
- iii. Enough water is available at streets fire hydrants, as the hydrant will draw water from the various branches lines
- iv. During repairs, only a small area of distribution is affected.

### Disadvantages

- i. A large number of cut-off valves are required
- ii. The system requires longer pipe lengths with larger diameters.
- iii. The analysis of discharge, pressure and velocities in the pipes is difficult and cumbersome.
- iv. The cost of pipe-laying is higher

### 3. Circular or ring system

- ✿ In circular or ring system, the supply main forms a ring around the distribution area.
- ✿ The branches are connected cross-wise to the mains and also to each other.
- ✿ This system is most reliable for a town with well planned streets and roads.
- ✿ The advantages and disadvantages of this system are the same as those of the grid iron system. However, in case of fire, a larger quantity of water is available, and the length of the distribution main is much larger.

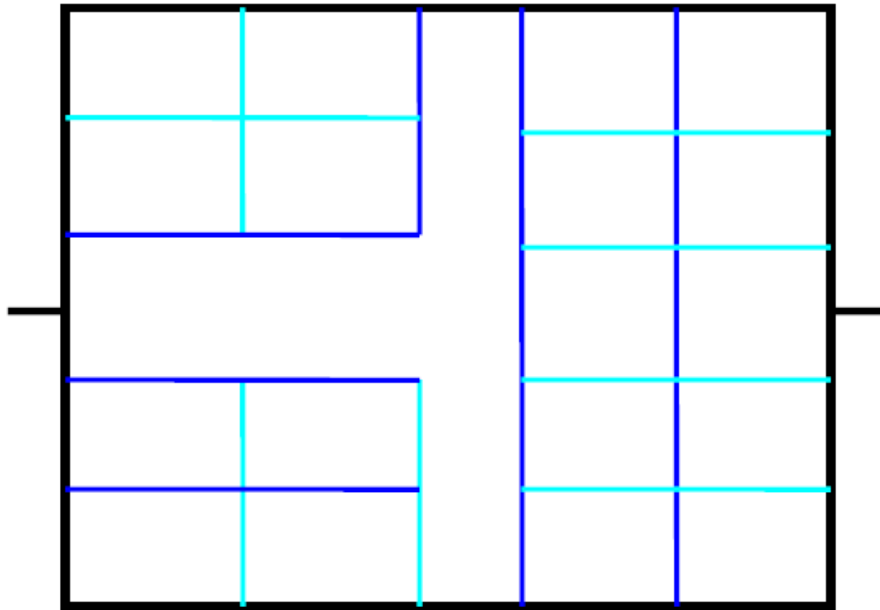

**Figure 3: Circular or ring distribution system**

### 4. Radial system

- ✿ In a radial system, the whole area is divided into a number of distribution districts.
- ✿ Each district has a centrally located distribution reservoir (elevated) from where distribution pipes run radially towards the periphery of the distribution district.
- ✿ This system provides swift service, without much loss of head.
- ✿ The design calculations are much simpler.

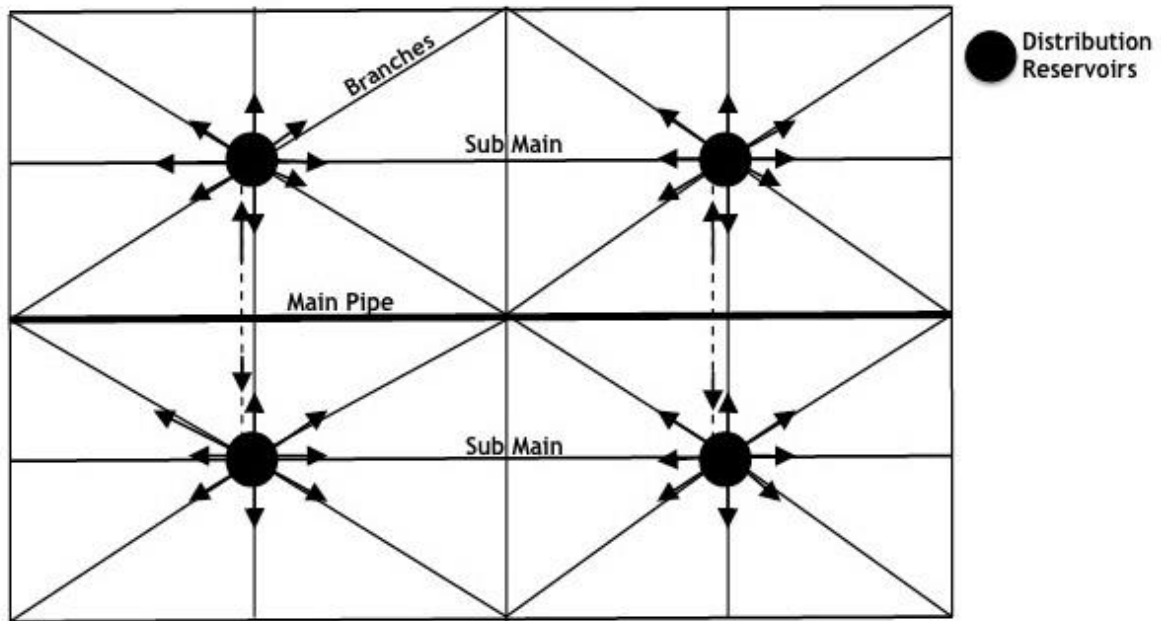

## LAYING JOINTING & TESTING OF PIPELINES

### Transport

- Pipes should be loaded at the works for transportation either by rail or by road.
- No movements can be take place on vehicle during the transit

### Off- Loading

- It should be carried out by means of chain block with shear log or crane
- Slings should be placed around the circumferential of the pipe and should not be threaded through the pipe bore.
- Hooks located at the ends of the pipes should not be used.

### Stacking

- Pipes can be directly placed on the ground free from rock and other projections.
- Stacking in tyres is permissible provided timber bearer is placed between succeeding tyres.

### Stringing

- It consists of placing of pipes on the ground in line ready for laying.

### Trench Excavation

- Trench should be sufficient width to provide a free working space.
- Free working place – not less than 150 mm on either side.



## **Inspection and Repairs**

### **1. Inspection of pipes before laying**

- Visually inspected for evidence of damage
- Examination of joint surfaces which may damage during transit.

### **2. Repairing Damaged Pipes**

- Minor damages may be repairable at site.

## **Laying**

- Lowered in to the trench with tackle suitable for the weight of pipe
- While lifting the position of the sling should be checked when the pipe is just clear off to ensure proper balance.
- Laying of pipe should be preferably proceed upgrade of a slope
- Expansion joints shall be provided for buried line at maximum interval of 100m but for exposed pipes shall not exceed 45 m.
- When laying is not in progress the open end of the pipe line should be fitted with temporary end closers.
- The pipe buoyant in the event of the trench become flooded and any movements of the pipes should be prevented either by partial refilling of the trench or by temporary strutting.

## **Jointing**

### **Basic requirements of joining of the pipelines are**

- Cleanliness of all the parts particularly joint surfaces
- Correct location of components
- Centralization of spigot within the socket
- Provision of the correct gap between the end of the spigot and the back of the socket to ensure flexibility at each joints
- Any lubrication used shall be approved as composition and method of application
- The section of the pipeline laid and jointed immediately to protect it from weather effects
- A minimum cover of 100 mm is considered adequate
- A polythene sheet also is used to cover the joints to prevent evaporation of water.
- A small change in the direction may be setting out adjacent pipe at a slight angle to one another.

## **Testing**

All pipe lines should be tested before come in service.

### **Hydrostatic Test**

- Filling the pipe line with water and raising pressure to selected limit.
- Draw graph between the quantity of water added and the time.

### ☒ **Site Test Pressure**

- Absorption of water by the pipe material under selected pressure
- The important factors of considerations are
  - The density of the pipe material.
  - Amount of surplus water present in the pipe at the commencement of test.
  - The amount and quality of cement matrix in case of concrete pipe
  - Thickness of the pipe unit under test
  - The pressure applied
  - The duration of the test.

The field test pressure to be imposed should not be less than the greatest of the following

- 1.5 times the maximum sustain operating pressure
- 1.5 times the maximum pipe line static pressure
- Sum of maximum sustained pressure and maximum surge pressure
- Sum of maximum pipeline static pressure and maximum surcharge pressure.
- The pressure should be applied and maintain for at least four hours, if there is no leakage then the pipe line is ok

### **Allowable leakage**

$$qL = \frac{ND}{P}$$

where

$qL =$  allowable leakage in  $cm^3$ /hour

$N =$  No. of joints in the length of pipe line

$D =$  Diametre in cm

$P =$  Average test pressure during leakage test in  $Kg/cm^2$

### **Leak detection**

- Visual inspection of each joints if not covered by back fill
- Use of a bar probe to detect signs of water in the vicinity of joints if backfilled
- Aural inspection using a stethoscope or listening stick in contact with pipeline
- Use of an electronic listening device which detect and amplifies the sound of escaping water
- Injection of dye into the test water
- Introduction of Nitrous oxide solution into the test water using IR- gas concentration; escaped through the leaks.

## Pumps for water supply

- Centrifugal pump
- Reciprocating pump
- Submergible pump
- Air lift pumps
- Rotary pumps

## CENTRIFUGAL PUMP

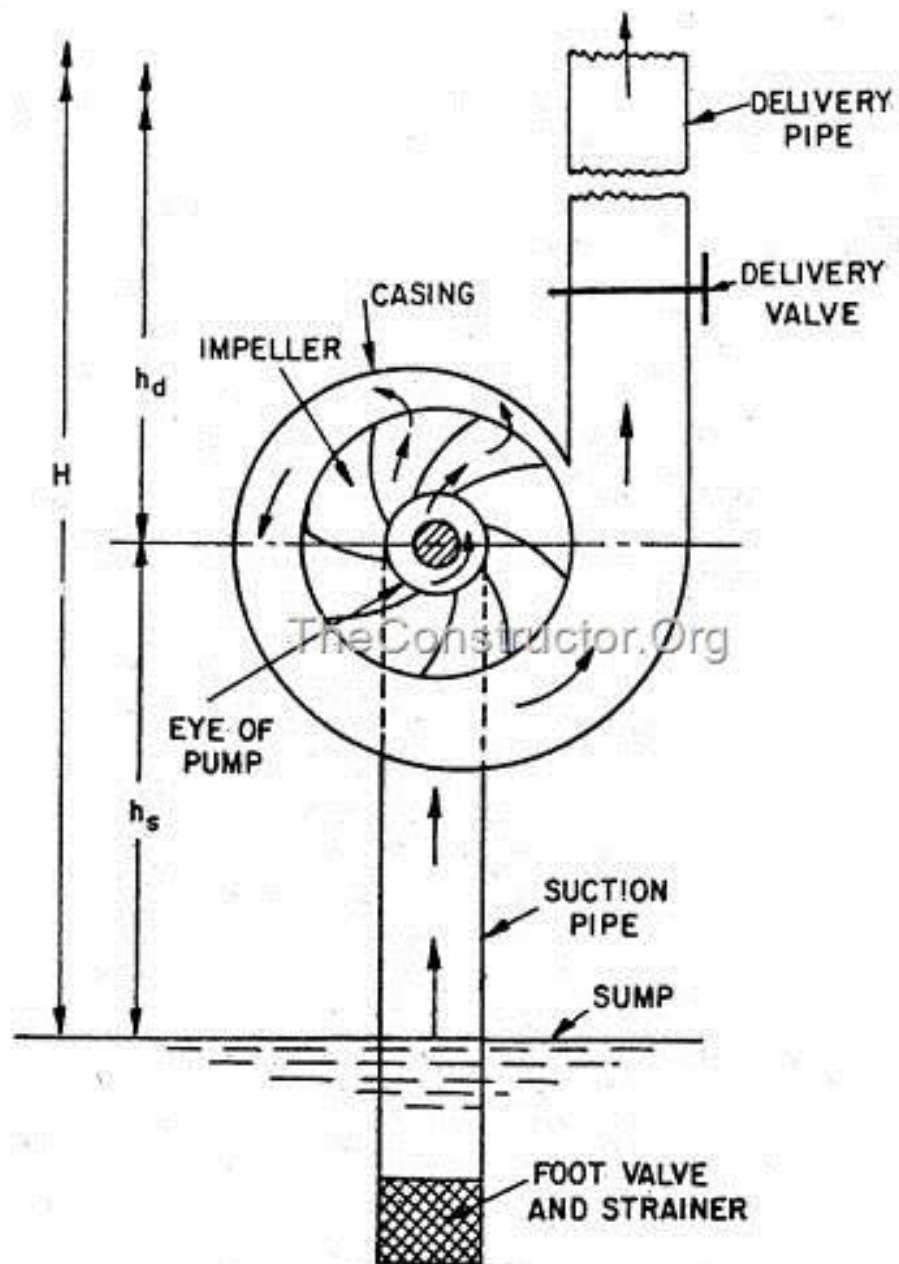

## RECIPROCATING PUMP

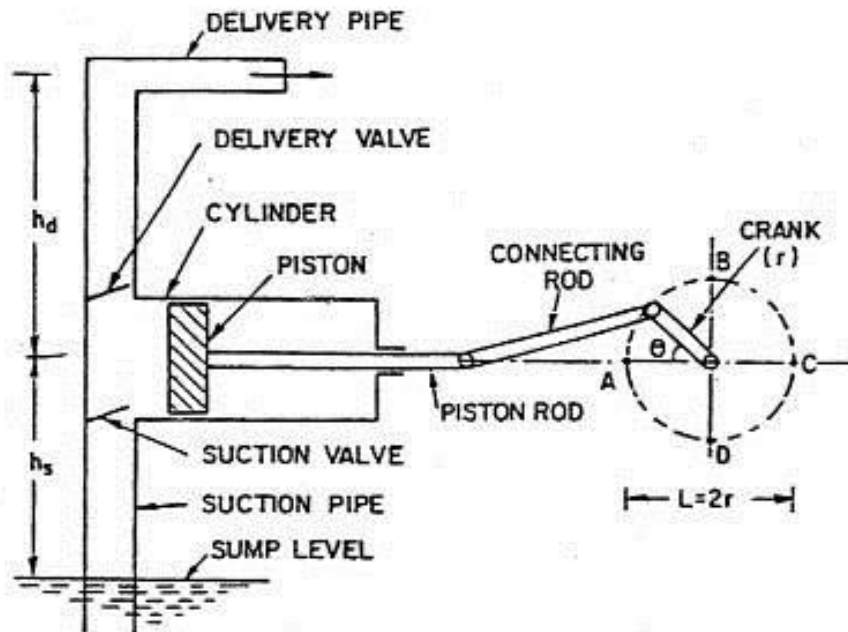

## AIR LIFT PUMPS

