

SYNCHRONOUS MOTOR DRIVES

5.1 Introduction

Synchronous motor drives are close competitors to induction motor drives in many industrial applications.

They are generally more expensive than induction motor drives, but the advantage is that the efficiency is higher, which tends to lower the life cycle cost.

The development of semiconductor variable frequency sources, such as inverters and cycloconverters has allowed their use in variable speed applications such as high power and high speed compressors, blowers, induced and forced draft fans, main line traction, servo drives etc...

Synchronous motor variable speed Drives

5.2 Variable frequency control

Synchronous speed is directly proportional to frequency, similar to induction motors constant flux operation below base speed is achieved by operating the synchronous motor with constant (V / f) ratio.

The synchronous motor either runs at synchronous speed (or) it will not run at all.

Hence variable frequency control may employ any of the following two modes

1. True synchronous mode
2. Separate controlled mode
3. Self controlled mode

5.3 SEPARATE CONTROLLED MODE

This method can also be used for smooth starting and regenerative braking. An example for true synchronous mode is the open loop (V/f) speed control shown in fig

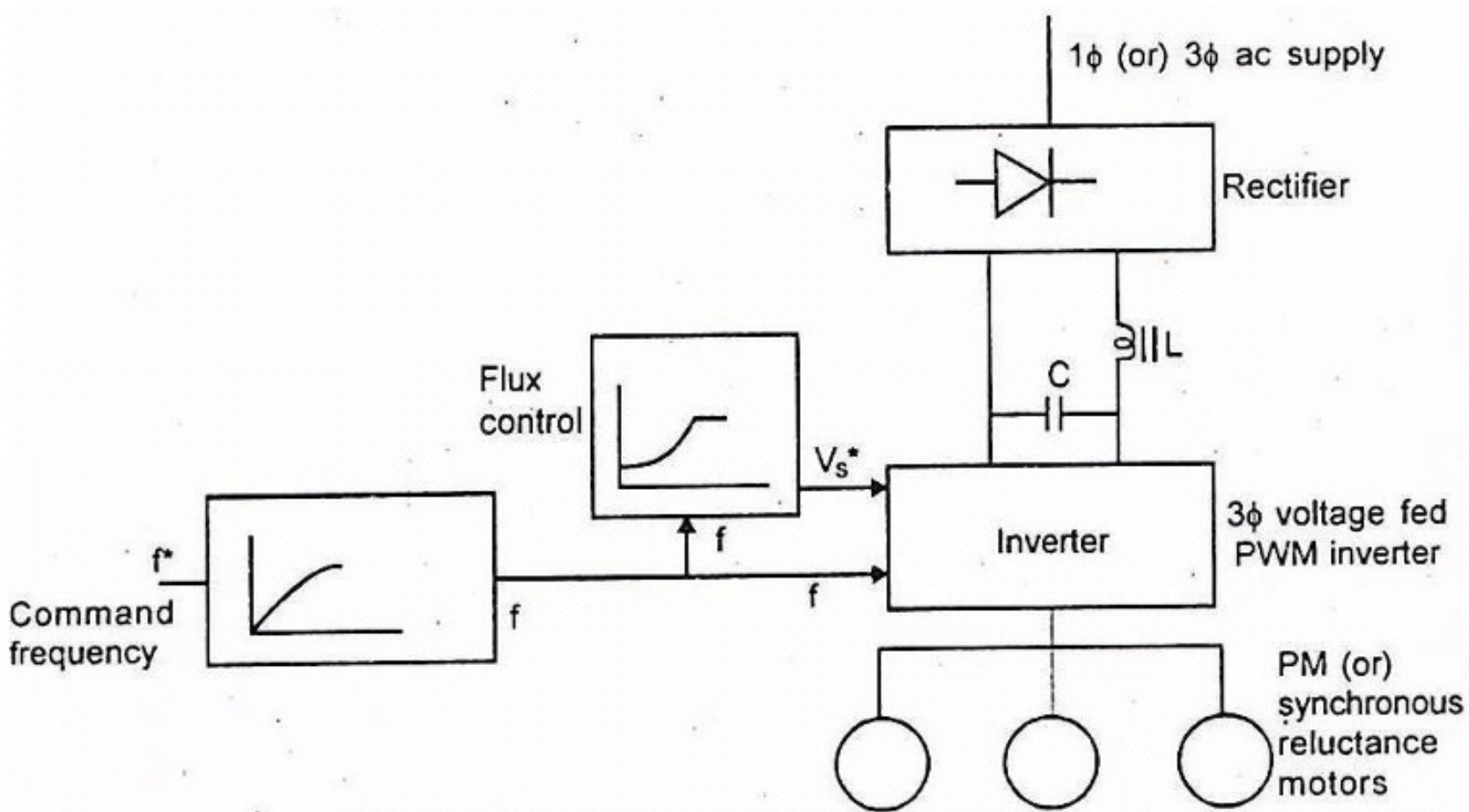

Fig (5.3) Separate Controlled Mode

Here all the machines are connected in parallel to the same inverter and they move in response to the command frequency f^* at the input. The frequency command f^* after passing through the delay circuit is applied to the voltage source inverters (or) a voltage fed PWM inverter. This is done so that the rotor source is able to track the change in frequency.

A flux control block is used which changes the stator voltage with frequency so as to maintain constant flux for speed below base speed and constant terminal voltage for speed above base speed.

The front end of the voltage fed PWM inverter is supplied from utility line through a diode rectifier and LC filter. the machine can be built with damper winding to prevent oscillations.

5.4 SELF CONTROLLED MODE

In self controlled mode, the supply frequency is changed so that the synchronous speed is same as that of the rotor speed. Hence, rotor cannot pull-out of slip and hunting eliminations are eliminated. For such a mode of operation the motor does not require a damper winding.

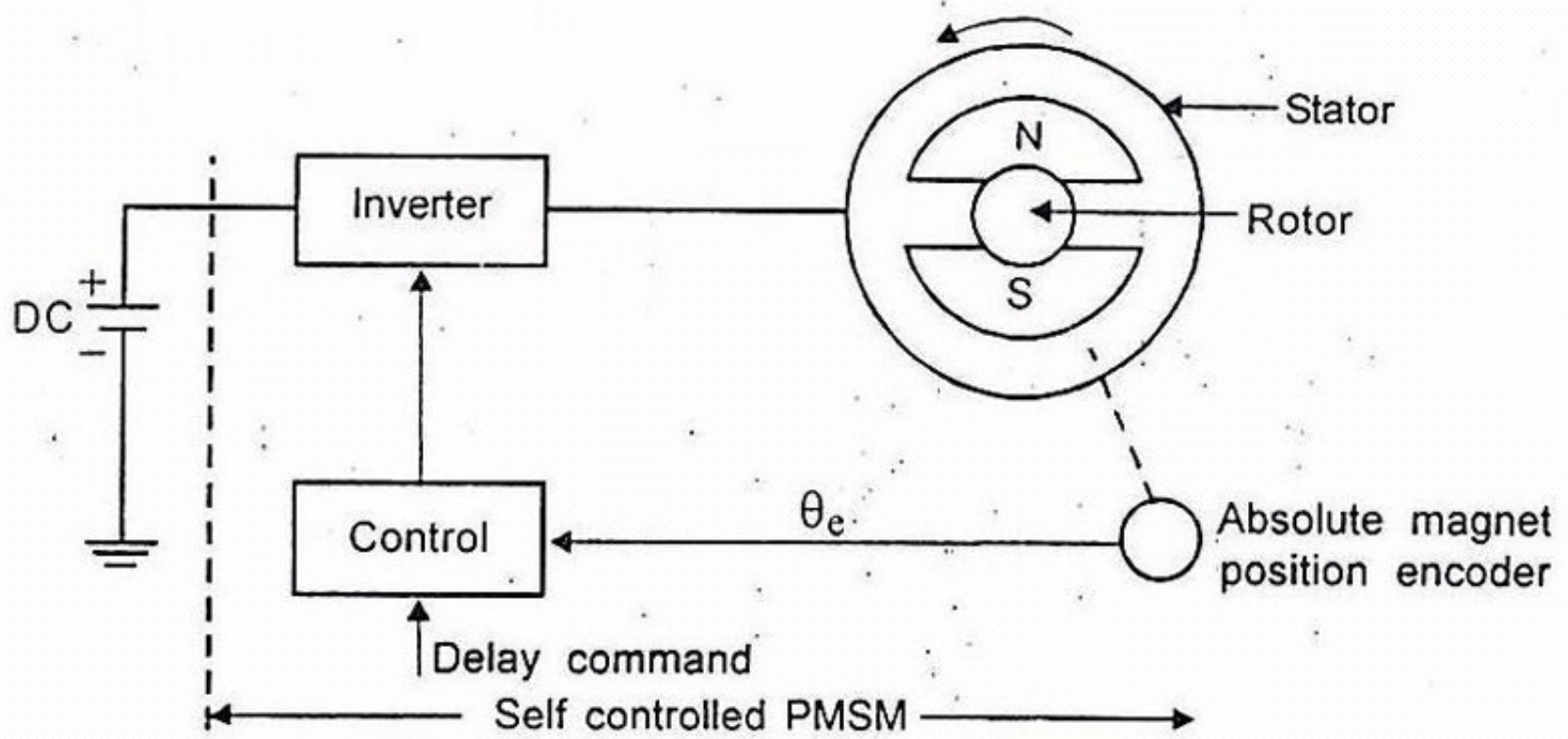

Fig (5.4)Self Controlled Mode

Fig shows a synchronous permanent magnet machine with self control. The stator winding of the machine is fed by an inverter that generates a variable frequency voltage sinusoidal supply.

Here the frequency and phase of the output wave are controlled by an absolute position sensor mounted on machine shaft, giving it self-control characteristics. Here the pulse train from position sensor may be delayed by the external command as shown in fig.

In this kind of control the machine behavior is decided by the torque angle and voltage/ current. Such a machine can be looked upon as a dc motor having its commutator replaced by a converter connected to stator. The self controlled motor run

has properties of a dc motor both under steady state and dynamic conditions and therefore, is called commutator less motor (CLM). These machines have better stability behavior.

Alternatively, the firing pulses for the inverters can also be obtained from the phase position of stator voltages in which case the rotor position sensor can be dispensed with.

When synchronous motor is over excited they can supply the reactive power required for commutation thyristors. In such a case the synchronous machine can supply with inverter works similar to the line commutated inverter where the firing signals are synchronized with line voltages.

Here, the firing signals are synchronized with the machine voltages then these voltages can be used both for control as well as for commutation. Hence, the frequency of the inverter will be same as that of the machine voltages. This type of inverters are called load commutated inverter (LCI). Hence the commutation has simple configurations due to the absence of diodes, capacitors and auxiliary thyristors.

But then this natural commutation its not possible at low speeds upto 10% of base speed as the machine voltage are insufficient to provide satisfactory commutation. At that line some forced commutations circuit must be employed.

5.5 Self controlled synchronous motor Drive empolying load commuated Thyristor Inverter

In fig wound field synchronous motor is used for large power drives. Permanent magnet synchronous motor is used for medium power drives. This drive consists of two converters. i.e source side converter and load side converter.

The source side converter is a 3 phase 6 pulse line commutated fully controlled rectifier .When the firing angle range $0 \leq \alpha \leq 90^\circ$, it acts as a commutated fully contrlled rectifier.

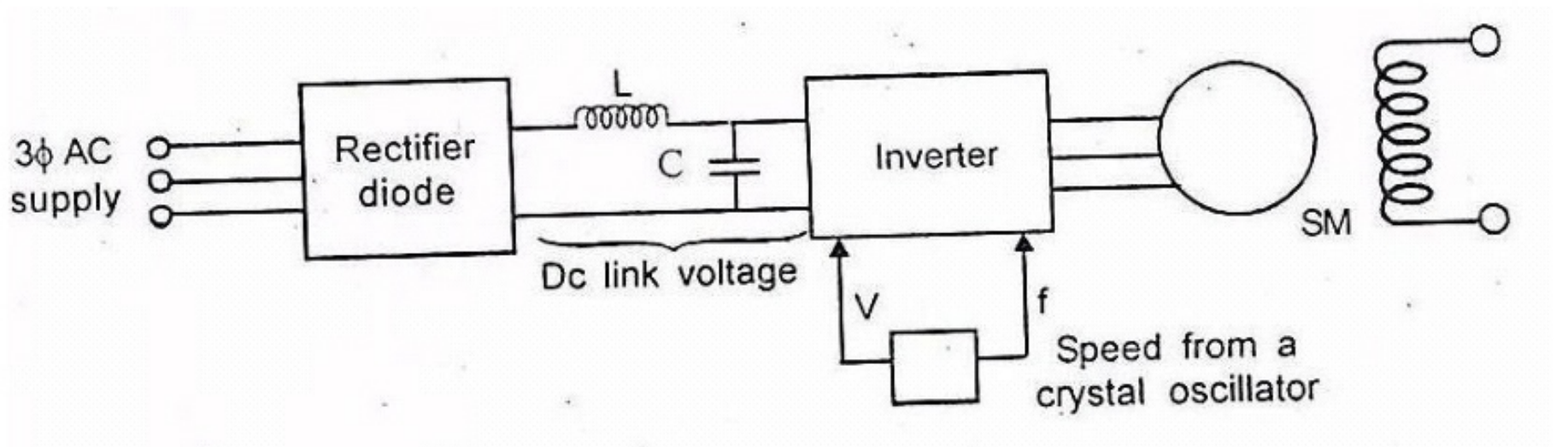

Separate control of SM fed from PWM inverter

Fig (5.5) Separate control of SM fed from PWM inverter

During this mode ,output volatge V_{ds} and output current I_{ds} is positive.When the firing angle range is $90^\circ \leq \alpha \leq 180^\circ$,it acts as an line commutated inverter.During this mode,output voltage V_{ds} is negative and output current I_{ds} is positive.

When synchronous motor operates at a leading power factor ,thyristors of the load side 3 ϕ converter can be commutated (turn off) by the motor induced voltages in the same way,as thyristors of a 3 ϕ line commutated converter are commutated by supply voltage .Load commutation is defined as commutation of thyristors by induced voltages of load (here load is synchronous motor).

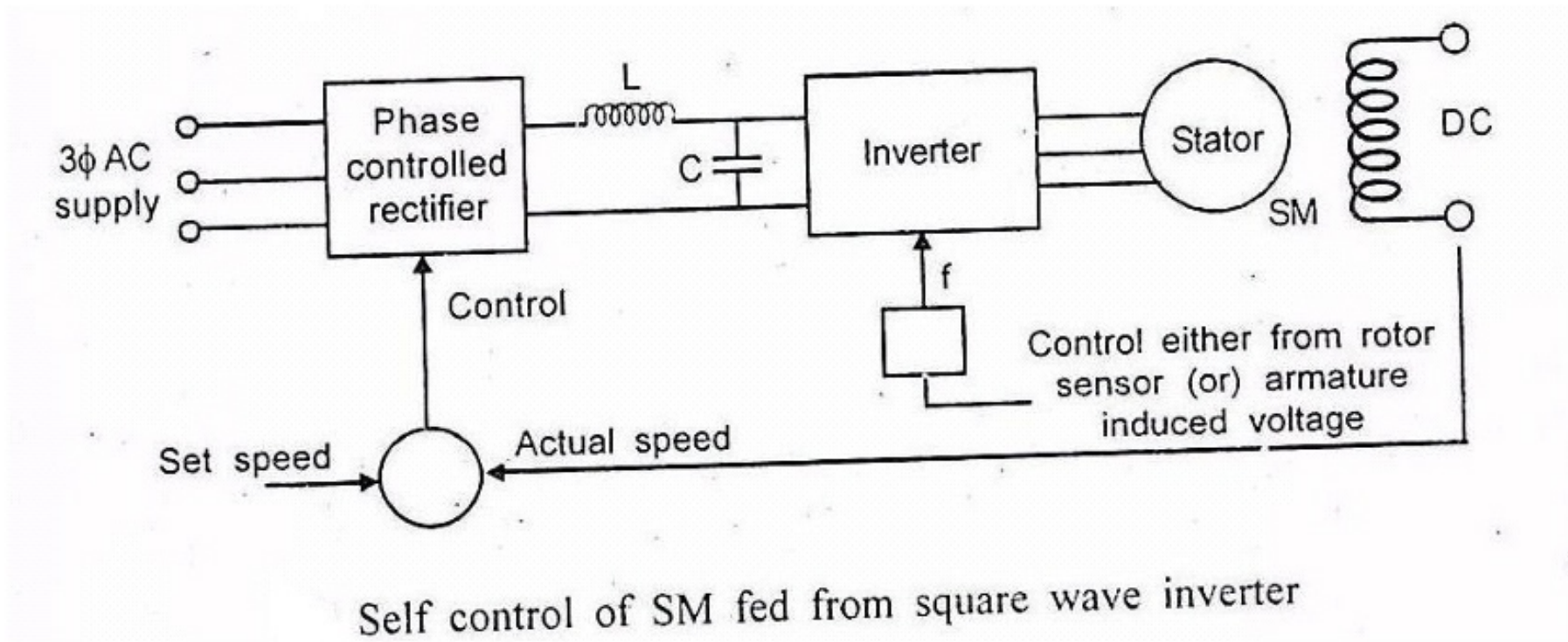

Self control of SM fed from square wave inverter

Fig (5.5.1) Self control of SM fed square wave inverter

Triggering angle is measured by comparison of induced voltage in the same way as by the comparison of supply voltages in a line commutated converter.Loas side converter operates as a rectifier when the firing angle range is $0 \leq \alpha \leq 90^\circ$.It gives positive V_{dl} and I_d .When the firing angle range is $90^\circ \leq \alpha \leq 180^\circ$,it gives negative V_{dl} and positive I_d .

For $0 \leq \alpha \leq 90^\circ$, $90^\circ \leq \alpha \leq 180^\circ$ and with $V_{ds} > V_{dl}$,the source side converter works as a line commutated rectifier and load side converter,causing power flow from ac source to the motor,thus giving motoring operation.

When firing angles are changed such that $90^\circ \leq \alpha \leq 180^\circ$ and $0^\circ \leq \alpha \leq 90^\circ$,the load side converter operates as a rectifier and source side converter operates as an inverter.In this condition ,the power flow reverses and machine operates in regerative braking.The magnitude of torque value depends on $(V_{ds} - V_{dl})$.Synchronous motor speed can be changed by control of line side converter firing angles.

When working as an inverter, the firing angle has to be less than 180° to take care of commutation overlap and turn off of thyristors. The commutation lead angle for load side converter is

$$\beta_l = 180^\circ - \alpha_l$$

if commutation overlap is neglected, the input ac current of the converter will lag behind input ac voltage by angle α_l . Here synchronous motor input current has an opposite phase to converter input current, the motor current will lead its terminal voltage by a commutation lead angle β_l .

Therefore the synchronous motor operates at a leading power factor. The commutation lead angle is low value, due to this higher the motor power factor and lower the inverter rating.

5.6 CONSTANT MARGINAL ANGLE

The operation of the inverter at the minimum safe value of the margin angle gives the highest power factor and the maximum torque per ampere of the armature current, thus allowing the most efficient use of both the inverter and motor.