

Module

3

DC to DC Converters

Lesson

22

Fly-Back Type Switched  
Mode Power Supply

After completion of this lesson the reader will be able to:

- (i) Identify the topology of a fly-back type switched mode power supply circuit.
- (ii) Explain the principle of operation of fly-back SMPS circuit.
- (iii) Calculate the ratings of devices and components used in fly-back converter for the specified input and output voltages and for the required output power.
- (iv) Design a simple fly-back converter circuit.

## 22.1 Introduction

Fly-back converter is the most commonly used SMPS circuit for low output power applications where the output voltage needs to be isolated from the input main supply. The output power of fly-back type SMPS circuits may vary from few watts to less than 100 watts. The overall circuit topology of this converter is considerably simpler than other SMPS circuits. Input to the circuit is generally unregulated dc voltage obtained by rectifying the utility ac voltage followed by a simple capacitor filter. The circuit can offer single or multiple isolated output voltages and can operate over wide range of input voltage variation. In respect of energy-efficiency, fly-back power supplies are inferior to many other SMPS circuits but its simple topology and low cost makes it popular in low output power range.

The commonly used fly-back converter requires a single controllable switch like, MOSFET and the usual switching frequency is in the range of 100 kHz. A two-switch topology exists that offers better energy efficiency and less voltage stress across the switches but costs more and the circuit complexity also increases slightly. The present lesson is limited to the study of fly-back circuit of single switch topology.

## 22.2 Basic Topology of Fly-Back Converter

Fig.22.1 shows the basic topology of a fly-back circuit. Input to the circuit may be unregulated dc voltage derived from the utility ac supply after rectification and some filtering. The ripple in dc voltage waveform is generally of low frequency and the overall ripple voltage waveform repeats at twice the ac mains frequency. Since the SMPS circuit is operated at much higher frequency (in the range of 100 kHz) the input voltage, in spite of being unregulated, may be considered to have a constant magnitude during any high frequency cycle. A fast switching device ('S'), like a MOSFET, is used with fast dynamic control over switch **duty ratio** (ratio of ON time to switching time-period) to maintain the desired output voltage. The transformer, in Fig.22.1, is used for voltage isolation as well as for better matching between input and output voltage and current requirements. Primary and secondary windings of the transformer are wound to have good coupling so that they are linked by nearly same magnetic flux. As will be shown in the next section the primary and secondary windings of the fly-back transformer don't carry current simultaneously and in this sense **fly-back transformer works differently from a normal transformer**. In a normal transformer, under load, primary and secondary windings conduct simultaneously such that the ampere turns of primary winding is nearly balanced by the opposing ampere-turns of the secondary winding (the small difference in ampere-turns is required to establish flux in the non-ideal core). Since primary and

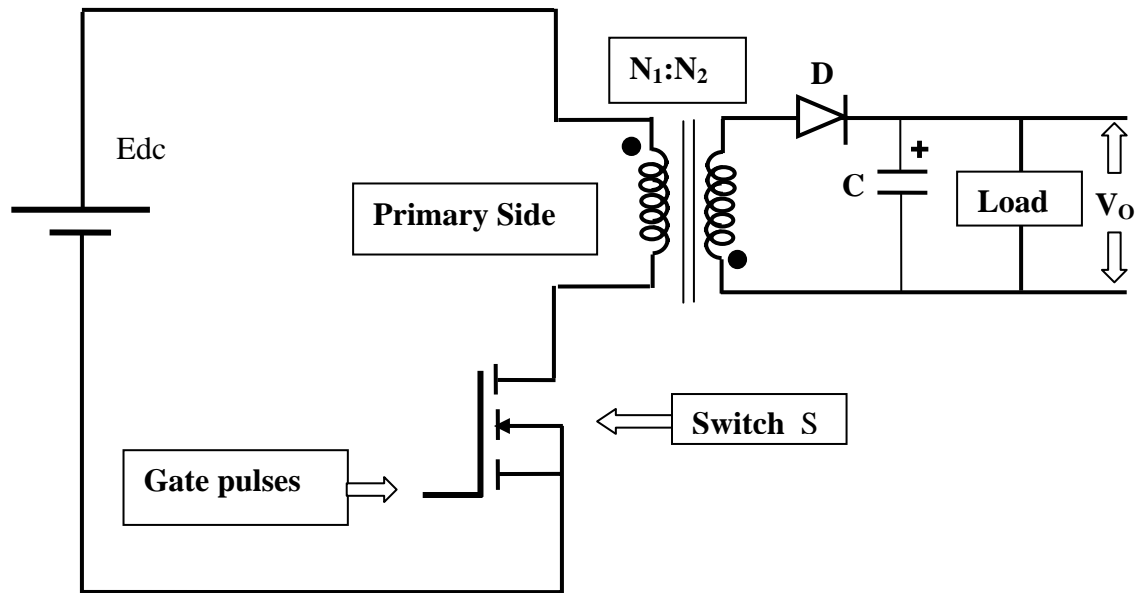

**Fig. 22.1 Fly Back Converter**

secondary windings of the fly-back transformer don't conduct simultaneously they are more like two magnetically coupled inductors and it may be more appropriate to call the fly-back transformer as inductor-transformer. Accordingly the magnetic circuit design of a fly-back transformer is done like that for an inductor. The details of the inductor-transformer design are dealt with separately in some later lesson. The output section of the fly-back transformer, which consists of voltage rectification and filtering, is considerably simpler than in most other switched mode power supply circuits. As can be seen from the circuit (Fig.22.1), the secondary winding voltage is rectified and filtered using just a diode and a capacitor. Voltage across this filter capacitor is the SMPS output voltage.

It may be noted here that the circuit shown in Fig.22.1 is rather schematic in nature. A more practical circuit will have provisions for output voltage and current feedback and a controller for modulating the duty ratio of the switch. It is quite common to have multiple secondary windings for generating multiple isolated voltages. One of the secondary outputs may be dedicated for estimating the load voltage as well as for supplying the control power to the circuit. Further, as will be discussed later, a snubber circuit will be required to dissipate the energy stored in the leakage inductance of the primary winding when switch 'S' is turned off.

Under this lesson, for ease of understanding, some simplifying assumptions are made. The magnetic circuit is assumed to be linear and coupling between primary and secondary windings is assumed to be ideal. Thus the circuit operation is explained without consideration of winding leakage inductances. ON state voltage drops of switches and diodes are neglected. The windings, the transformer core, capacitors etc. are assumed loss-less. The input dc supply is also assumed to be ripple-free.

**[A brief idea of a more practical fly-back converter will be given towards the end of this lesson.]**

## 22.3 Principle of Operation

During its operation fly-back converter assumes different circuit-configurations. Each of these circuit configurations have been referred here as modes of circuit operation. The complete operation of the power supply circuit is explained with the help of functionally equivalent circuits in these different modes.

As may be seen from the circuit diagram of Fig.22.1, when switch 'S' is on, the primary winding of the transformer gets connected to the input supply with its dotted end connected to the positive side. At this time the diode 'D' connected in series with the secondary winding gets reverse biased due to the induced voltage in the secondary (dotted end potential being higher). Thus with the turning on of switch 'S', primary winding is able to carry current but current in the secondary winding is blocked due to the reverse biased diode. The flux established in the transformer core and linking the windings is entirely due to the primary winding current. This mode of circuit has been described here as **Mode-1 of circuit operation**. Fig. 22.2(a) shows (in bold line) the current carrying part of the circuit and Fig. 22.2(b) shows the circuit that is functionally equivalent to the fly-back circuit during mode-1. In the equivalent circuit shown, the conducting switch or diode is taken as a shorted switch and the device that is not conducting is taken as an open switch. This representation of switch is in line with our assumption where the switches and diodes are assumed to have ideal nature, having zero voltage drop during conduction and zero leakage current during off state.

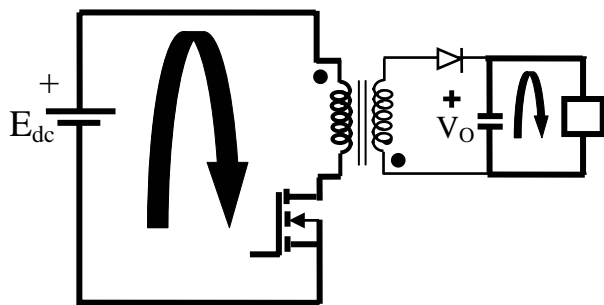

Fig.22.2(a): Current path during Mode-1 of circuit operation

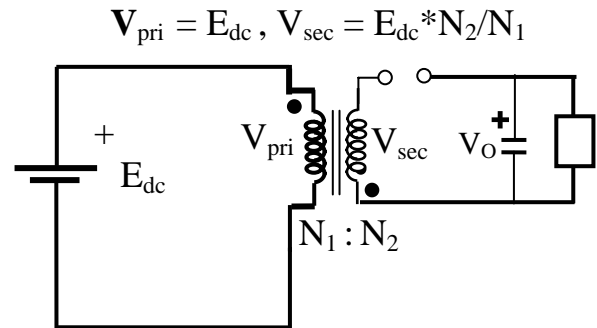

Fig.22.2(b): Equivalent circuit in Mode-1

Under Mode-1, the input supply voltage appears across the primary winding inductance and the primary current rises linearly. The following mathematical relation gives an expression for current rise through the primary winding:

$$E_{DC} = L_{Pri} \times \frac{d}{dt} i_{Pri} \text{-----(22.1),}$$

where  $E_{DC}$  is the input dc voltage,  $L_{Pri}$  is inductance of the primary winding and  $i_{Pri}$  is the instantaneous current through primary winding.

Linear rise of primary winding current during mode-1 is shown in Fig.22.5(a) and Fig.22.5(b). As described later, the fly-back circuit may have continuous flux operation or discontinuous flux operation. The waveforms in Fig.22.5(a) and Fig.22.5(b) correspond to circuit operations in continuous and discontinuous flux respectively. In case the circuit works in continuous flux mode, the magnetic flux in the transformer core is not reset to zero before the next cyclic turning ON of switch 'S'. Since some flux is already present before 'S' is turned on, the primary winding

current in Fig. 22.3(a) abruptly rises to a finite value as the switch is turned on. Magnitude of the current-step corresponds to the primary winding current required to maintain the previous flux in the core.

At the end of switch-conduction (i.e., end of Mode-1), the energy stored in the magnetic field of the fly back inductor-transformer is equal to  $L_{pri}I_p^2/2$ , where  $I_p$  denotes the magnitude of primary current at the end of conduction period. Even though the secondary winding does not conduct during this mode, the load connected to the output capacitor gets uninterrupted current due to the previously stored charge on the capacitor. During mode-1, assuming a large capacitor, the secondary winding voltage remains almost constant and equals to  $V_{sec} = E_{DC} \times N_2 / N_1$ . During mode-1, dotted end of secondary winding remains at higher potential than the other end. Under this condition, voltage stress across the diode connected to secondary winding (which is now reverse biased) is the sum of the induced voltage in secondary and the output voltage ( $V_{diode} = V_o + E_{DC} \times N_2 / N_1$ ).

**Mode-2 of circuit operation** starts when switch ‘S’ is turned off after conducting for some time. The primary winding current path is broken and according to laws of magnetic induction, the voltage polarities across the windings reverse. Reversal of voltage polarities makes the diode in the secondary circuit forward biased. Fig. 22.3(a) shows the current path (in bold line) during mode-2 of circuit operation while Fig. 22.3(b) shows the functional equivalent of the circuit during this mode.

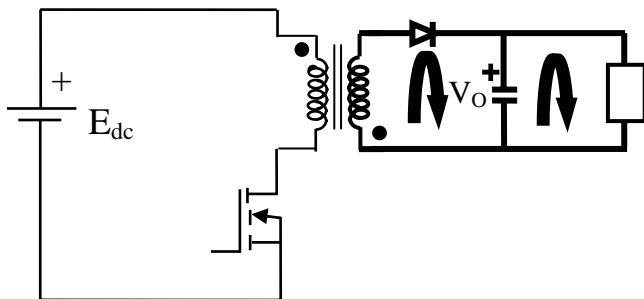

**Fig:22.3(a) : Current path during Mode-2 of circuit operation**

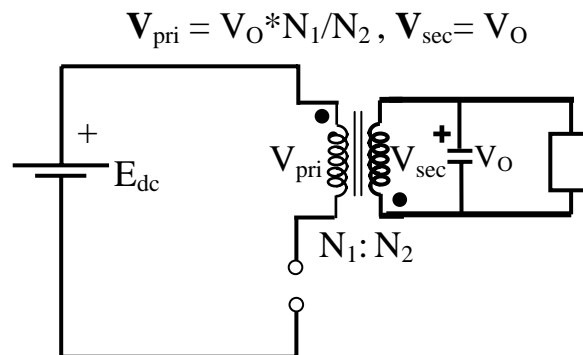

**Fig.22.3(b): Equivalent circuit in Mode-2**

In mode-2, though primary winding current is interrupted due to turning off of the switch ‘S’, the secondary winding immediately starts conducting such that the net **mmf** produced by the windings do not change abruptly. (**mmf is magneto motive force that is responsible for flux production in the core. Mmf, in this case, is the algebraic sum of the ampere-turns of the two windings. Current entering the dotted ends of the windings may be assumed to produce positive mmf and accordingly current entering the opposite end will produce negative mmf.**) Continuity of mmf, in magnitude and direction, is automatically ensured as sudden change in mmf is not supported by a practical circuit for reasons briefly given below.

[**mmf is proportional to the flux produced and flux, in turn, decides the energy stored in the magnetic field (energy per unit volume being equal to  $B^2/2\mu$ , B being flux per unit area and  $\mu$  is the permeability of the medium).** Sudden change in flux will mean sudden

**change in the magnetic field energy and this in turn will mean infinite magnitude of instantaneous power, some thing that a practical system cannot support.]**

For the idealized circuit considered here, the secondary winding current abruptly rises from zero to  $I_p N_1/N_2$  as soon as the switch 'S' turns off.  $N_1$  and  $N_2$  denote the number of turns in the primary and secondary windings respectively. The sudden rise of secondary winding current is shown in Fig. 22.5(a) and Fig. 22.5(b). The diode connected in the secondary circuit, as shown in Fig.22.1, allows only the current that enters through the dotted end. It can be seen that the magnitude and current direction in the secondary winding is such that the mmf produced by the two windings does not have any abrupt change. The secondary winding current charges the output capacitor. The + marked end of the capacitor will have positive voltage. The output capacitor is usually sufficiently large such that its voltage doesn't change appreciably in a single switching cycle but over a period of several cycles the capacitor voltage builds up to its steady state value.

**The steady-state magnitude of output capacitor voltage depends on various factors, like, input dc supply, fly-back transformer parameters, switching frequency, switch duty ratio and the load at the output.** Capacitor voltage magnitude will stabilize if during each switching cycle, the energy output by the secondary winding equals the energy delivered to the load.

As can be seen from the steady state waveforms of Figs.22.5(a) and 22.5(b), the secondary winding current decays linearly as it flows against the constant output voltage ( $V_o$ ). The linear decay of the secondary current can be expressed as follows:  $L_{sec} \times \frac{d}{dt} i_{sec} = -V_o$  ----- (22.2),

Where,  $L_{sec}$  and  $i_{sec}$  are secondary winding inductance and current respectively.

$V_o$  is the stabilized magnitude of output voltage.

Under steady-state and under the assumption of zero on-state voltage drop across diode, the secondary winding voltage during this mode equals  $V_o$  and the primary winding voltage =  $V_o N_1/N_2$  (dotted ends of both windings being at lower potential). Under this condition, voltage stress across switch 'S' is the sum total of the induced emf in the primary winding and the dc supply voltage ( $V_{switch} = E_{DC} + V_o N_1/N_2$ ).

The secondary winding, while charging the output capacitor (and feeding the load), starts transferring energy from the magnetic field of the fly back transformer to the power supply output in electrical form. If the off period of the switch is kept large, the secondary current gets sufficient time to decay to zero and magnetic field energy is completely transferred to the output capacitor and load. Flux linked by the windings remain zero until the next turn-on of the switch, and the circuit is under discontinuous flux mode of operation. Alternately, if the off period of the switch is small, the next turn on takes place before the secondary current decays to zero. The circuit is then under continuous flux mode of operation.

During discontinuous mode, after complete transfer of the magnetic field energy to the output, the secondary winding emf as well as current fall to zero and the diode in series with the winding stops conducting. The output capacitor however continues to supply uninterrupted voltage to the load. This part of the circuit operation has been referred to as **Mode-3** of the circuit operation.

Mode-3 ends with turn ON of switch 'S' and then the circuit again goes to Mode-1 and the sequence repeats.

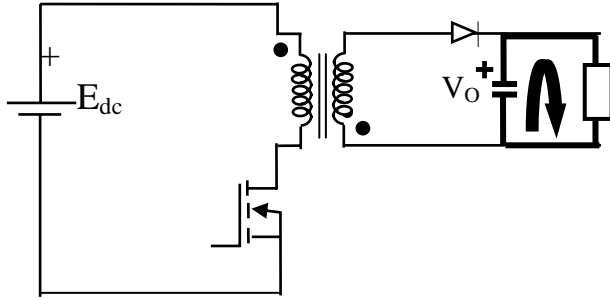

**Fig:22.4 (a) : Current flow path during Mode-3 of circuit operation**

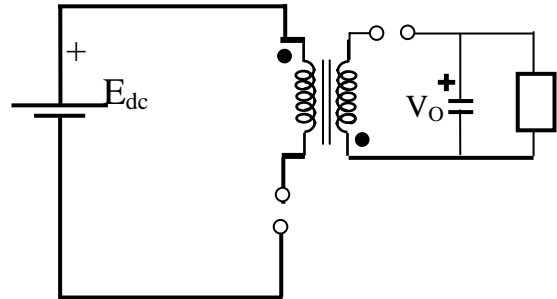

**Fig.22.4(b): Equivalent circuit in Mode-3**

Figs.22.4(a) and 22.4(b) respectively show the current path and the equivalent circuit during mode-3 of circuit operation. Figs.22.5(a) and 22.5(b) show, the voltage and current waveforms of the winding over a complete cycle. It may be noted here that even though the two windings of the fly-back transformer don't conduct simultaneously they are still coupled magnetically (linking the same flux) and hence the induced voltages across the windings are proportional to their number of turns.



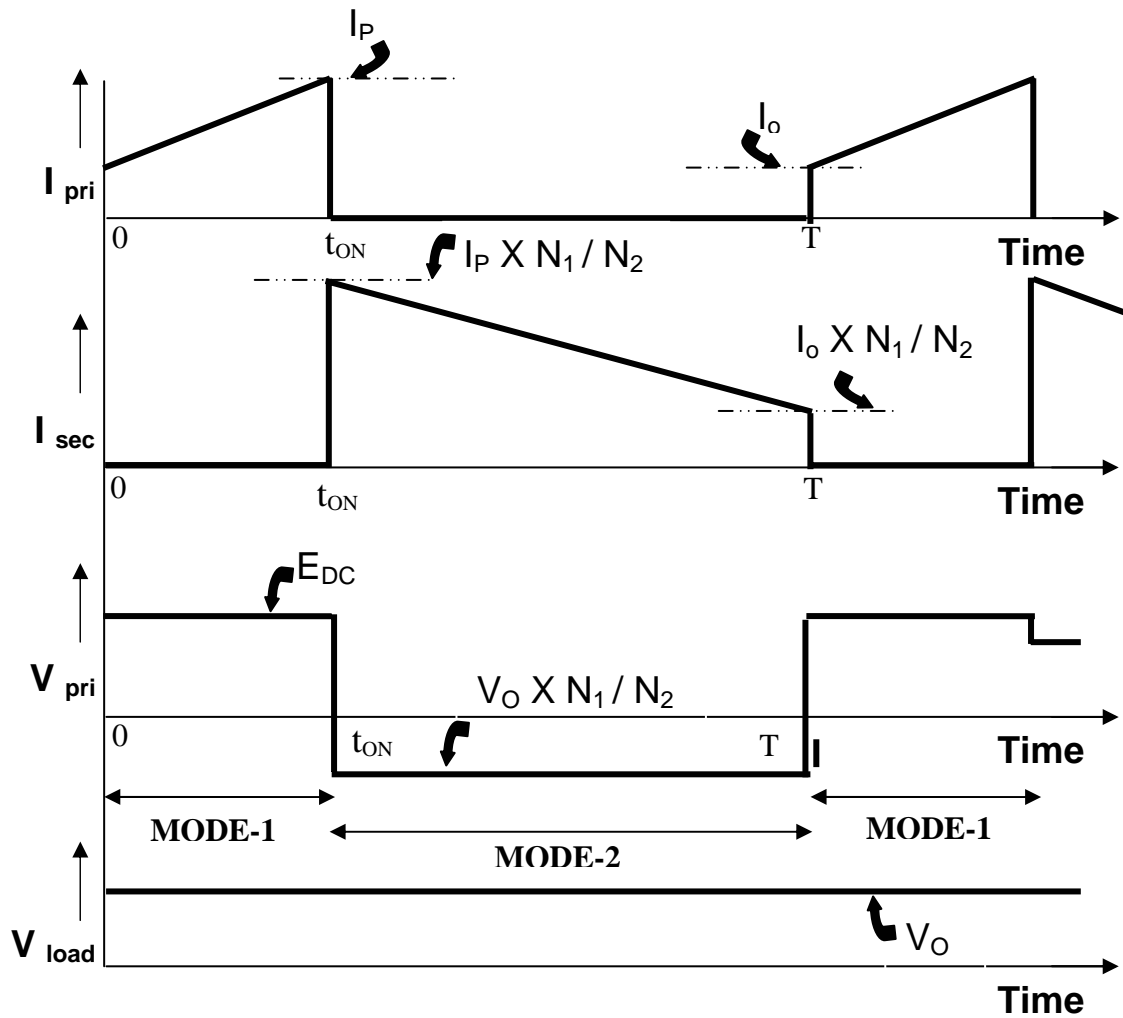

Fig.22.5(a): Fly-back circuit waveforms under continuous magnetic flux

## 22.4 Circuit Equations Under Continuous-Flux Operation

The waveforms in Fig.22.5(a) correspond to steady state operation under continuous magnetic flux. 't<sub>ON</sub>' denotes the time for which the fly-back switch is ON during each switching cycle. 'T' stands for the time period of the switching cycle. The ratio ( t<sub>ON</sub>/T) is known as the duty cycle (δ) of the switch. As can be seen from Fig.22.5(a), the primary winding current rises from I<sub>0</sub> to I<sub>P</sub> in 'δT' time. In terms of input supply voltage (E<sub>dc</sub>) and the primary winding inductance (L<sub>Pri</sub>) the following relation holds:

$$(I_P - I_0) = (E_{dc} / L_{Pri}) \delta T \text{ -----(22.3),}$$

Under steady state the energy input to primary winding during each ON duration equals: **0.5E<sub>dc</sub> (I<sub>P</sub> + I<sub>0</sub>) δT** and similarly the output energy in each cycle equals **V<sub>0</sub> I<sub>Load</sub> T**, where V<sub>0</sub> is the output voltage magnitude and I<sub>Load</sub> denotes the load current. Equating energy input and energy output of the converter (the converter was assumed loss-less) in each supply cycle, one gets:

$$0.5E_{dc} (I_P + I_0) \delta = V_0 I_{Load} \text{ -----(22.4),}$$

The mean (dc) voltage across both primary and secondary windings must be zero under every steady state. When the switch is ON, the primary winding voltage equals input supply voltage and when the switch is OFF the reflected secondary voltage appears across the primary winding. Under the assumption of ideal switch and diode,

$$E_{dc} \delta = (N_1 / N_2) V_0 (1-\delta) \text{ -----(22.5),}$$

where N<sub>1</sub> and N<sub>2</sub> are the number of turns in primary and secondary windings and (N<sub>1</sub>/N<sub>2</sub>)V<sub>0</sub> is the reflected secondary voltage across the primary winding (dotted end of the windings at lower potential) during mode-2 of circuit operation.

One needs to know the required ratings for the switch and the diode used in the converter. When the switch is OFF, it has to block a voltage (V<sub>switch</sub>) that equals to the sum of input voltage and the reflected secondary voltage during mode-2.

$$\text{Thus, } V_{switch} = E_{dc} + (N_1 / N_2) V_0 \text{ -----(22.6),}$$

When the switch is ON, the diode has to block a voltage (V<sub>diode</sub>) that equals to the sum of output voltage and reflected primary voltage during mode-1, i.e.,

$$V_{diode} = V_0 + E_{dc} (N_2 / N_1) \text{ -----(22.6a)}$$

Since the intended switching frequency for SMPS circuits is generally in the range of 100kHz, the switch and the diode used in the fly-back circuit must be capable of operating at high frequency. The switch and the transformer primary winding must be rated to carry a repetitive peak current equal to I<sub>P</sub> (related to maximum output power as given by Eqns. 22.3 to 22.5). Similarly the secondary winding and the diode put in the secondary circuit must be rated to carry a repetitive peak current equal to the maximum expected load current. The magnetic core of the high frequency inductor-transformer must be chosen properly such that the core does not saturate even when the primary winding carries the maximum expected current. Also, the transformer

core (made of ferrite material) must have low hysteresis loss even at high frequency operation. Since the ferrite cores have very low conductivity, the eddy current related loss in the core is generally insignificant.

## 22.5 Circuit Equations Under Discontinuous-Flux Mode

Fig. 22.5(b) shows some of the important voltage and current waveforms of the fly-back circuit when it is operating in the discontinuous flux mode. During mode-3 of the circuit operation, primary and secondary winding currents as well as voltages are zero. The load, however, continues to get a reasonably steady voltage due to the relatively large output filter capacitor.

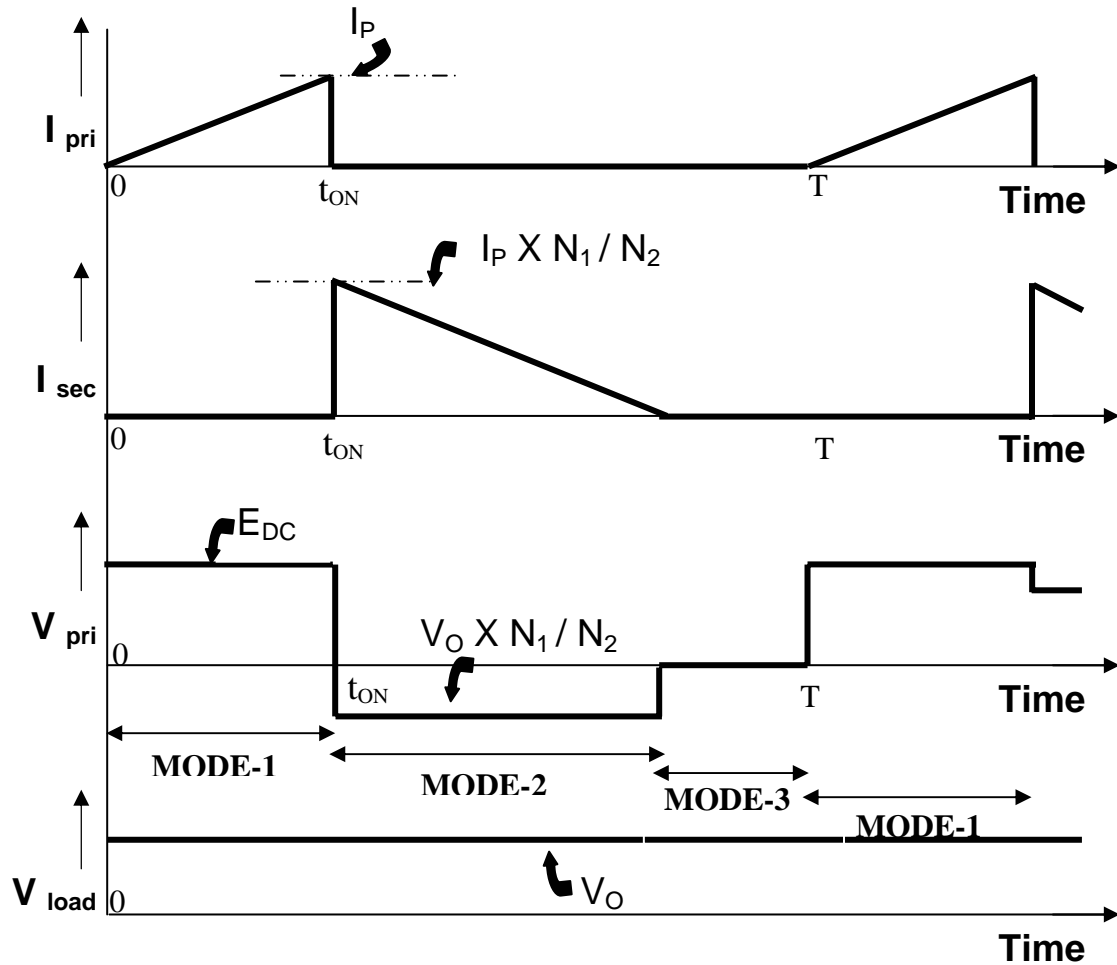

**Fig.22.5(b): Fly-back circuit waveforms under discontinuous flux**

With the turning ON of the switch, the primary winding current starts building up linearly from zero and at the end of mode-1 the magnetic field energy due to primary winding current rises to  $\frac{1}{2} L_{pri} I_P^2$ . This entire energy is transferred to the output at the end of mode-2 of circuit operation.

Under the assumption of loss-less operation the output power ( $P_o$ ) can be expressed as:

$$P_o = \frac{1}{2} L_{pri} I_P^2 f_{switch} \text{ -----(22.7),}$$

where  $f_{\text{switch}} (=1/T)$  is the switching frequency of the converter.

It may be noted that output power  $P_o$  is same as ' $V_o I_{\text{Load}}$ ' used in Eqn.(22.4). The volt-time area equation as given in Eqn.(22.5) gets modified under discontinuous flux mode of operation as follows:

$$E_{\text{dc}} \delta \leq (N_1 / N_2) V_o (1-\delta) \text{-----}(22.8)$$

Average voltage across windings over a switching cycle is still zero. The inequality sign of Eqn.22.8 is due to the fact that during part of the OFF period of the switch [=  $(1-\delta)T$ ], the winding voltages are zero. This zero voltage duration had been identified earlier as mode-3 of the circuit operation. The equality sign in Eqn.(22.8) will correspond to just-continuous case, which is the boundary between continuous and discontinuous mode of operation. The expression for  $V_{\text{switch}}$  and  $V_{\text{diode}}$ , as given in Eqns.(22.6) and (22.6a), will hold good in discontinuous mode also.

## 22.6 Continuous Versus Discontinuous Flux Mode of Operation

A practical fly-back type SMPS circuit will have a closed loop control circuit for output voltage regulation. The controller modulates the duty ratio of the switch to maintain the output voltage within a small tolerable ripple voltage band around the desired output value. If the load is very light, very small amount of energy needs to be input to the circuit in each switching cycle. This is achieved by keeping the ON duration of the switch low, resulting in low duty ratio ( $\delta$ ). Within this small ON time only a small amount of current builds up in the primary winding. The off duration of the switch, which is  $(1-\delta)$  fraction of the switching time period, is relatively large. Mode-2 duration of the circuit operation is also small as the magnetic field energy is quickly discharged into the output capacitor. Thus, at light load, the circuit is in mode-3 for significant duration. As the load increases the mode-3 duration, during which there is zero winding currents and zero flux through the core, reduces and the circuit is driven towards continuous flux mode. The circuit operation changes from discontinuous to continuous flux mode if the output power from the circuit increases beyond certain value. Similarly if the applied input voltage decreases, keeping the load power and switching frequency constant, the circuit tends to go in continuous flux mode of operation.

For better control over output voltage, discontinuous flux mode of operation is preferred. However, for the given transformer and switch ratings etc., more output power can be transferred during continuous flux mode. A common design thumb rule is to design the circuit for operation at just-continuous flux mode at the minimum expected input voltage and at the maximum (rated) output power.

## 22.7 A Practical Fly-Back Converter

The fly-back converter discussed in the previous sections neglects some of the practical aspects of the circuit. The simplified and idealized circuit considered above essentially conveys the basic idea behind the converter. However a practical converter will have device voltage drops and losses, the transformer shown will also have some losses. The coupling between the primary and secondary windings will not be ideal. The loss part of the circuit is to be kept in mind while designing for rated power. The designed input power ( $P_{\text{in}}$ ) should be equal to  $P_o/\eta$ , where  $P_o$  is the required output power and  $\eta$  is the efficiency of the circuit. A typical figure for  $\eta$  may be

taken close to 0.6 for first design iteration. Similarly one needs to counter the effects of the non-ideal coupling between the windings. Due to the non-ideal coupling between the primary and secondary windings when the primary side switch is turned-off some energy is trapped in the leakage inductance of the winding. The flux associated with the primary winding leakage inductance will not link the secondary winding and hence the energy associated with the leakage flux needs to be dissipated in an external circuit (known as snubber). Unless this energy finds a path, there will be a large voltage spike across the windings which may destroy the circuit.

Fig.22.6 shows a practical fly-back converter. The snubber circuit consists of a fast recovery diode in series with a parallel combination of a snubber capacitor and a resistor. The leakage-inductance current of the primary winding finds a low impedance path through the snubber diode to the snubber capacitor. It can be seen that the diode end of the snubber capacitor will be at higher potential. To check the excessive voltage build up across the snubber capacitor a resistor is put across it. Under steady state this resistor is meant to dissipate the leakage flux energy. The power lost in the snubber circuit reduces the overall efficiency of the fly-back type SMPS circuit. A typical figure for efficiency of a fly-back circuit is around 65% to 75%. In order that snubber capacitor does not take away any portion of energy stored in the mutual flux of the windings, the minimum steady state snubber capacitor voltage should be greater than the reflected secondary voltage on the primary side. This can be achieved by proper choice of the snubber-resistor and by keeping the RC time constant of the snubber circuit significantly higher than the switching time period. Since the snubber capacitor voltage is kept higher than the reflected secondary voltage, the worst-case switch voltage stress will be the sum of input voltage and the peak magnitude of the snubber capacitor voltage.

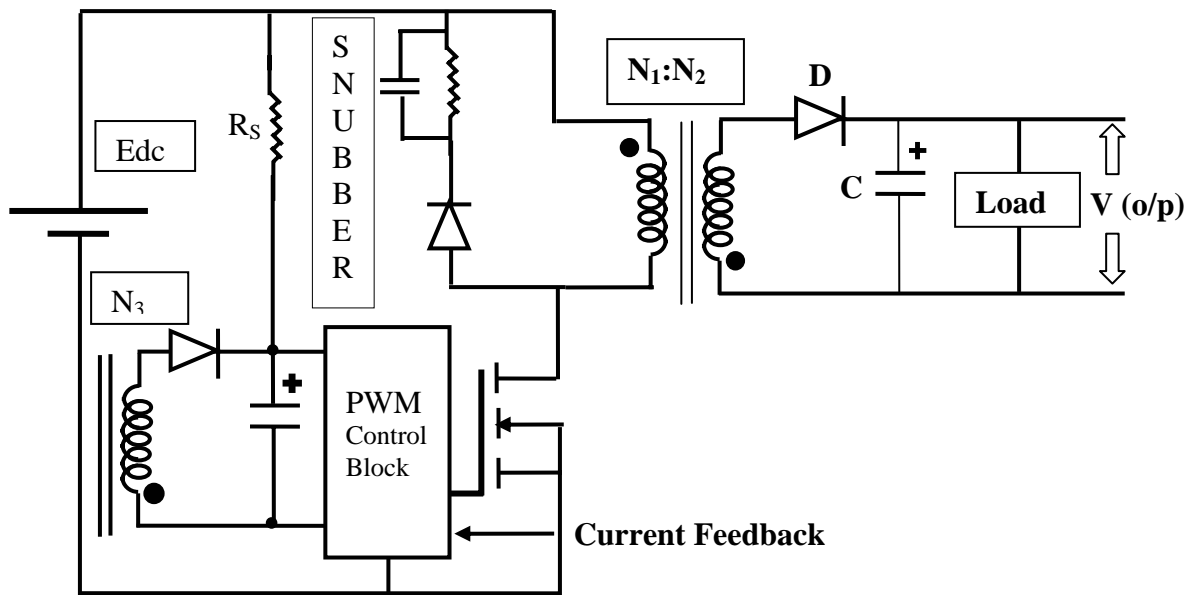

**Fig. 22.6 A Practical Fly Back Converter**

The circuit in Fig.22.6 also shows, in block diagram, a Pulse Width Modulation (PWM) control circuit to control the duty ratio of the switch. In practical fly-back circuits, for closed loop output voltage regulation, one needs to feed output voltage magnitude to the PWM controller. In order to maintain ohmic isolation between the output voltage and the input switching circuit the output voltage signal needs to be isolated before feeding back. A popular way of feeding the isolated voltage information is to use a tertiary winding. The tertiary winding voltage is rectified in a way

similar to the rectification done for the secondary winding. The rectified tertiary voltage will be nearly proportional to the secondary voltage multiplied by the turns-ratio between the windings. The rectified tertiary winding voltage also doubles up as control power supply for the PWM controller. For initial powering up of the circuit the control power is drawn directly from the input supply through a resistor (shown as  $R_S$  in Fig.22.6) connected between the input supply and the capacitor of the tertiary circuit rectifier. The resistor ' $R_S$ ' is of high magnitude and causes only small continuous power loss.

In case, multiple isolated output voltages are required, the fly-back transformer will need to have multiple secondary windings. Each of these secondary winding voltages are rectified and filtered separately. Each rectifier and filter circuit uses the simple diode and capacitor as shown earlier for a single secondary winding. In the practical circuit shown above, where a tertiary winding is used for voltage feedback, it may not be possible to compensate exactly for the secondary winding resistance drop as the tertiary winding is unaware of the actual load supplied by the secondary winding. However for most applications the small voltage drop in the winding resistance may be tolerable. Else, one needs to improve the voltage regulation by adding a linear regulator stage in tandem (as mentioned in Chapter-21) or by giving a direct output voltage feedback to the control circuit.

## Quiz Problems

- (i) What kind of output rectifier and filter circuit is used in a fly back converter?
- (a) a four-diode bridge rectifier followed by a capacitor
  - (b) a single diode followed by an inductor-capacitor filter
  - (c) a single diode followed by a capacitor
  - (d) will require a center-tapped secondary winding followed by a full wave rectifier and a output filter capacitor.
- (ii) A fly-back converter operates in discontinuous conduction mode with fixed ON duration of the switch in each switching cycle. Assuming input voltage and the resistive load at the output to remain constant, how will the output voltage change with change in switching frequency? (Assume discontinuous conduction through out and neglect circuit losses.)
- (a) Output voltage varies directly with switching frequency.
  - (b) Output voltage varies inversely with switching frequency.
  - (c) Output voltage varies directly with square root of switching frequency.
  - (d) Output voltage is independent of switching frequency.
- (iii) A fly-back converter has primary to secondary turns ratio of 15:1. The input voltage is constant at 200 volts and the output voltage is maintained at 18 volts. What should be the snubber capacitor voltage under steady state?
- (a) More than 270 volts.
  - (b) More than 200 volts but less than 270 volts.
  - (c) Less than 18 volts.
  - (d) Not related to input or output voltage.

(iv) A fly-back converter is to be designed to operate in just-continuous conduction mode when the input dc is at its minimum expected voltage of 200 volts and when the load draws maximum power. The load voltage is regulated at 16 volts. What should be the primary to secondary turns ratio of the transformer if the switch duty ratio is limited to 80%. Neglect ON-state voltage drop across switch and diodes.

- (a) 20 :1
- (b) 30 :1
- (c) 25 :2
- (d) 50 :1

**Answers to quiz problems: (i-c), (ii-c), (iii-a), (iv-d).**